

Universidad Nacional de Avellaneda

Departamento de Arquitectura, Diseño y Urbanismo | Arquitectura
Sistemas de Representación II |

- Figura humana
- Contexto urbano + verde
- Sombreado
- Color
- Énfasis en la IDEA



La figura humana



Continuous Monument (1969), Superstudio.

La figura humana



Archigram. Fotomontaje.

La figura humana

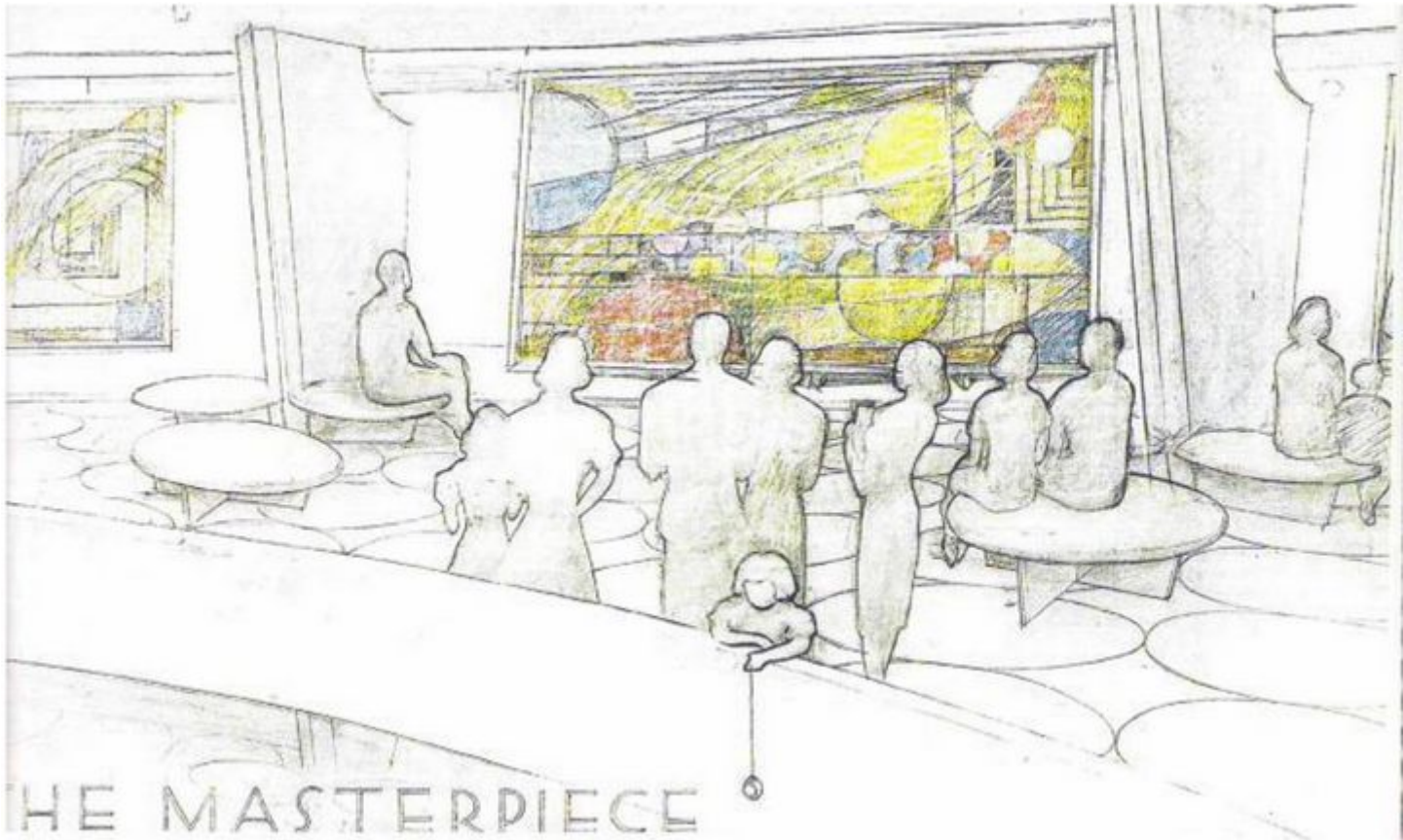

Guggenheim Museum (1943-1959) Frank Lloyd Wright.

La figura humana

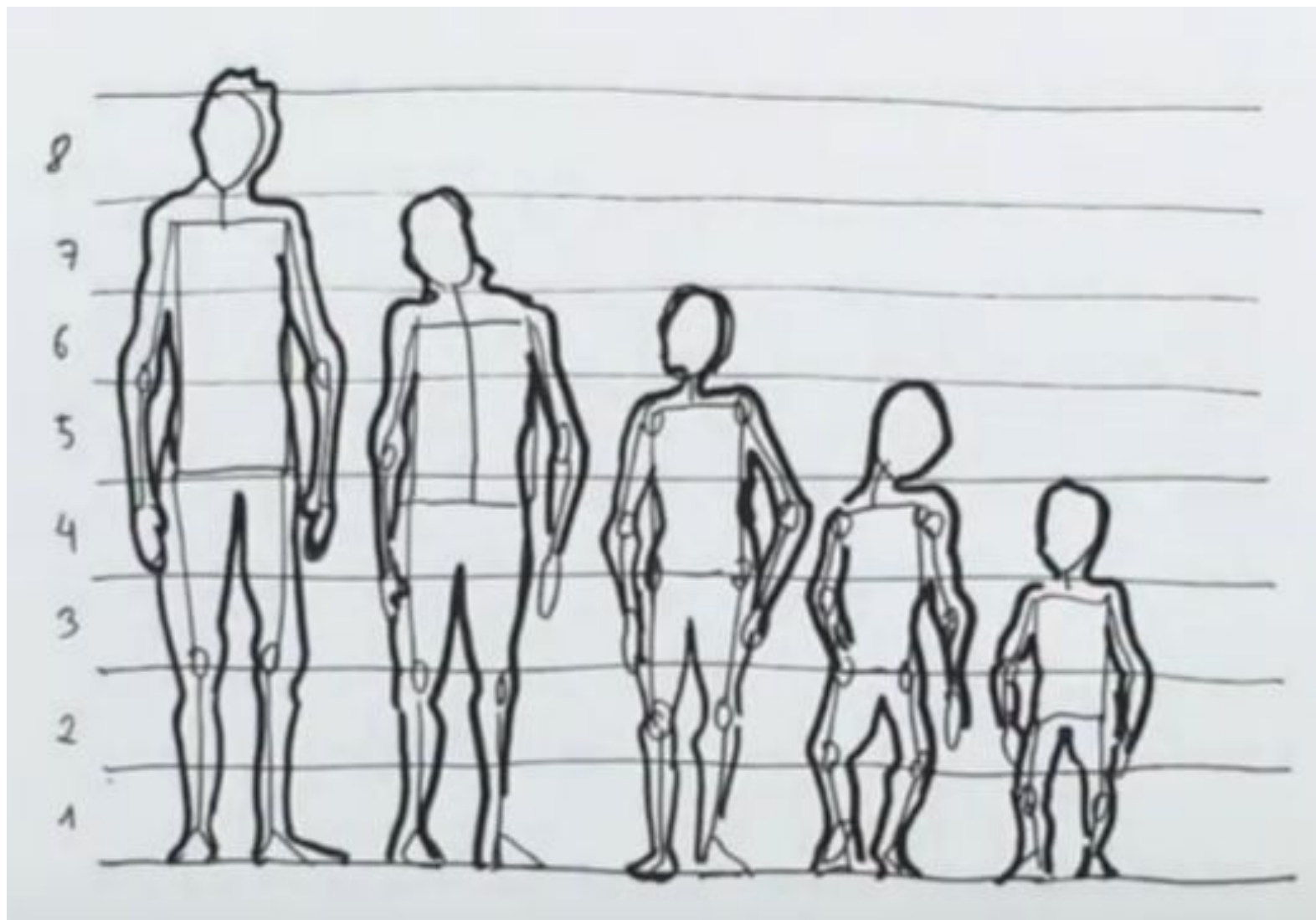

La figura humana



[Un ensayo fotográfico sobre la cosificación del cuerpo en la ergonomía de Neufert](http://paulgisbrecht.com)
paulgisbrecht.com

La figura humana



Andrew Geller



Norman Foster



Claude Parent



Le Corbusier



Alvaro Siza



Renzo Piano



Santiago Calatrava



Frank Gehry



Oscar Niemeyer



Glenn Murcutt



C. F. Møller



Steven Holl



Gian Lorenzo Bernini

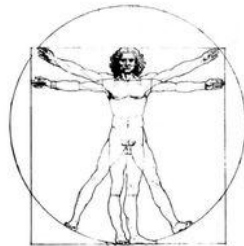

Leonardo Da Vinci



Peter Cook



Theo van Doesburg



SANAA



Walter Gropius

"These Architects' Drawings of Human Figures Offer an Insight Into Their Minds"

La figura humana

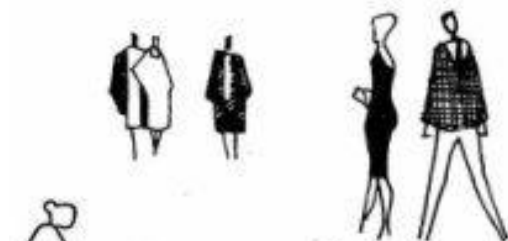
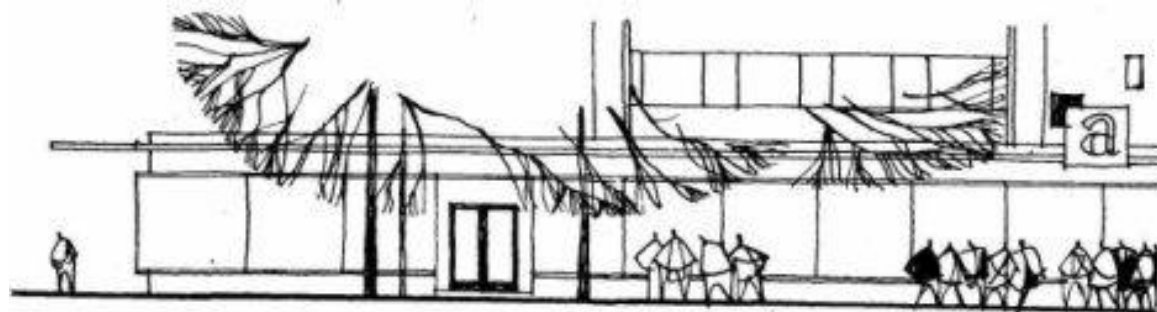

TEMA:
Contexto urbano + verde

La vegetación

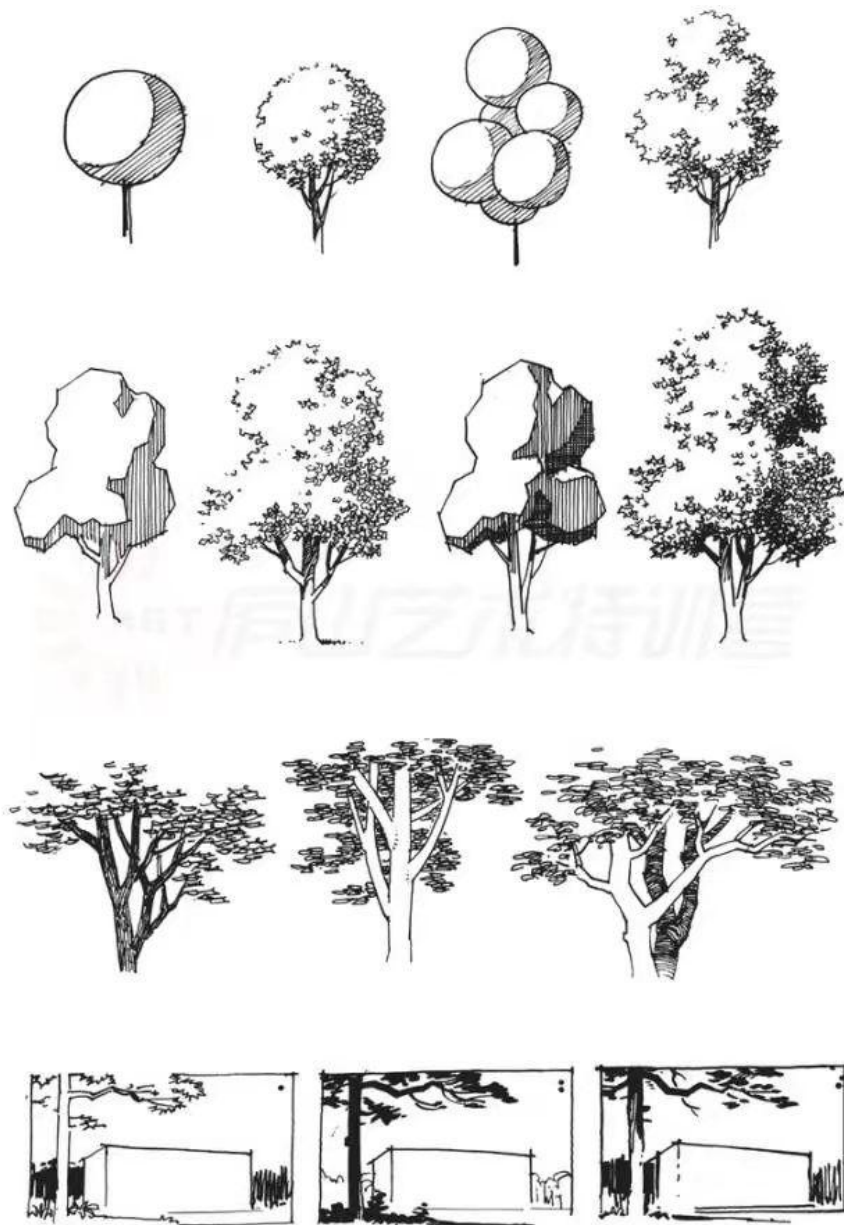

La vegetación



La vegetación

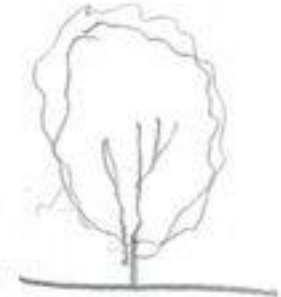
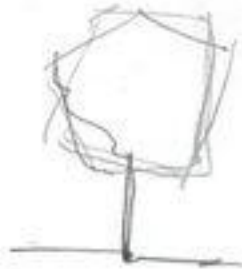

El equipamiento urbano

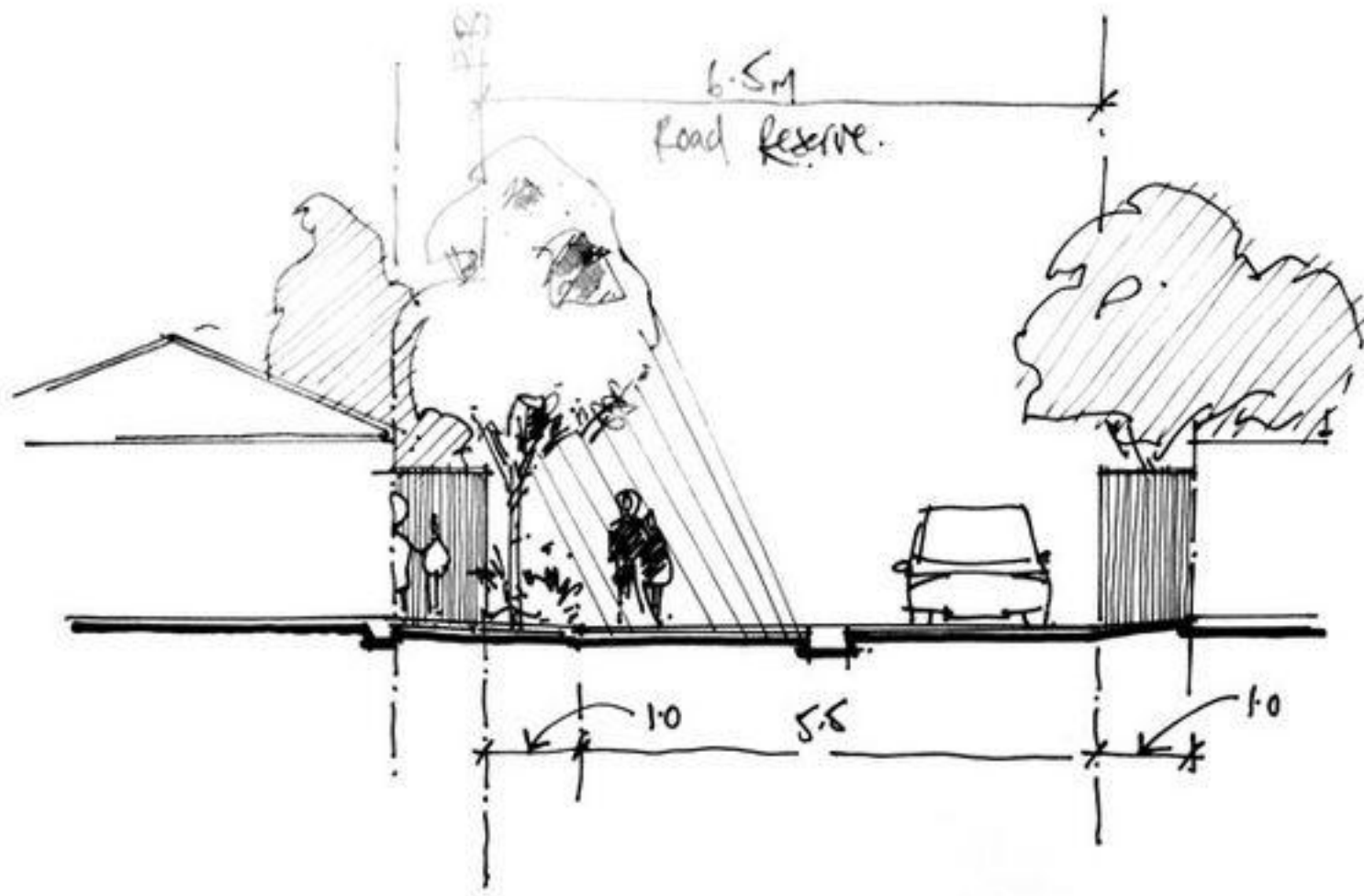

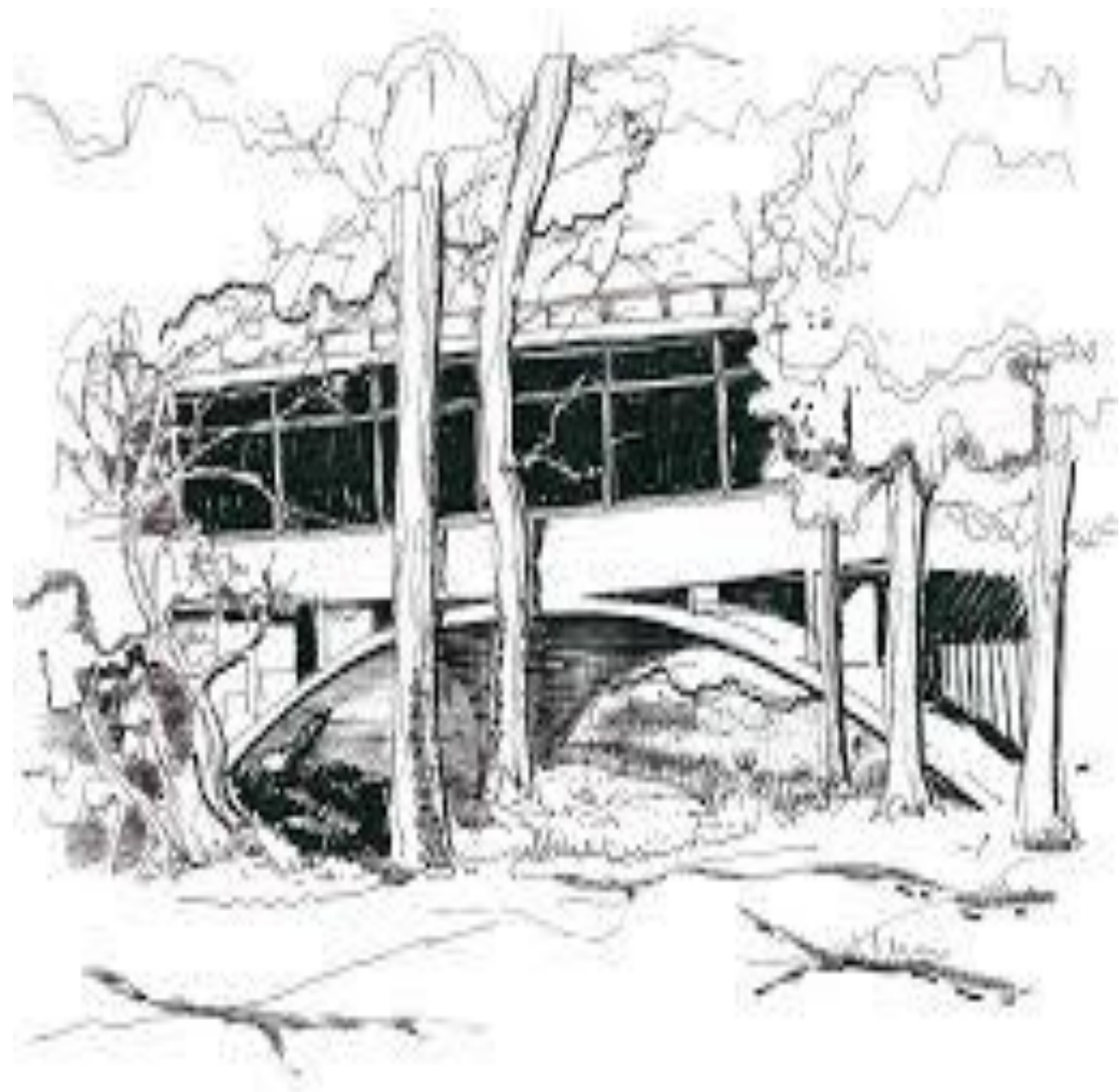

Síntesis

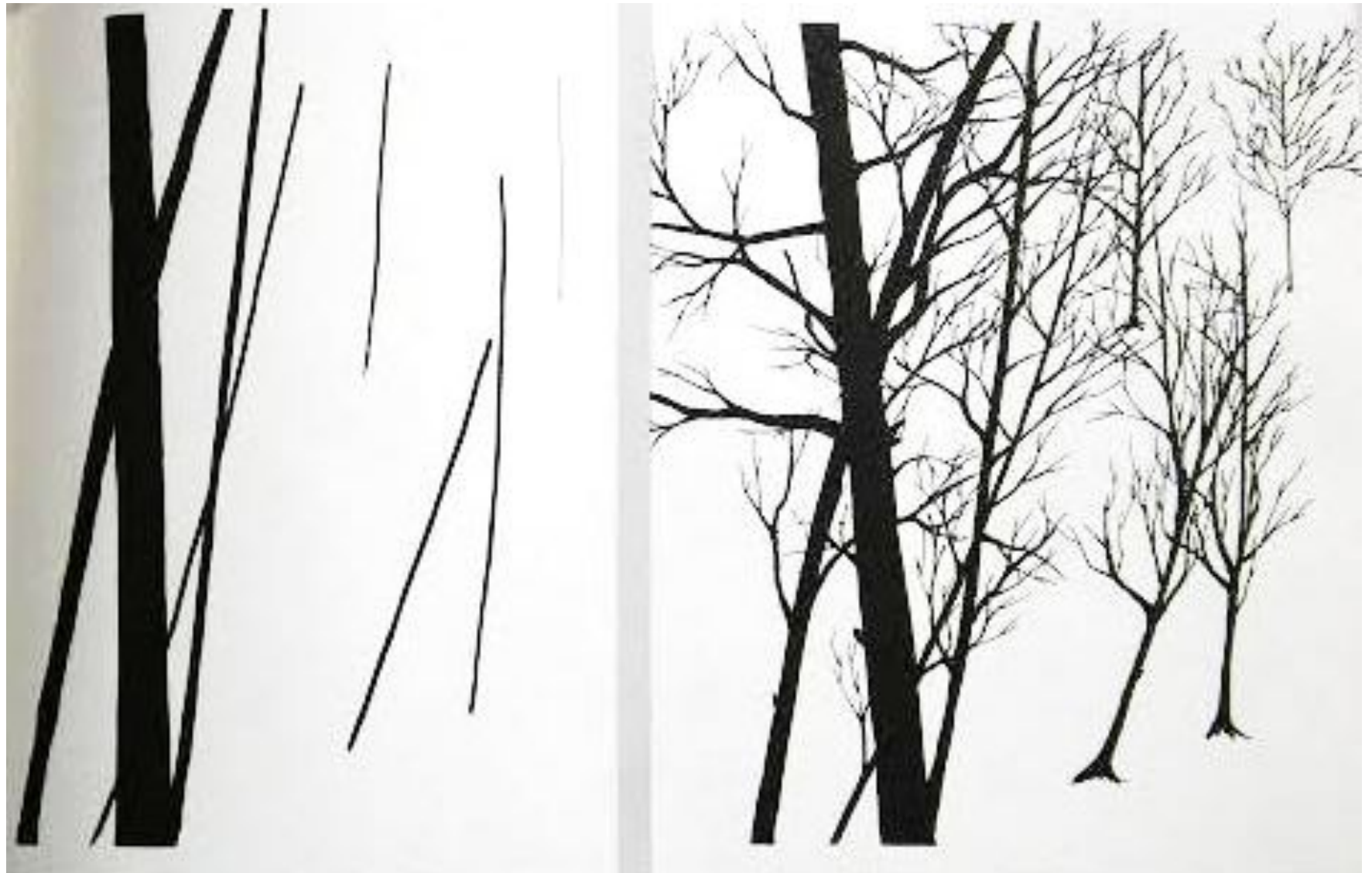



TEMA:
Énfasis en la IDEA

Enfatizando la forma

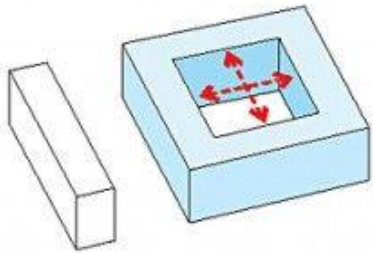

TRADITIONAL BLOCK

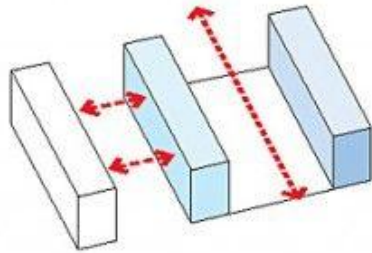

OPENING THE BLOCK

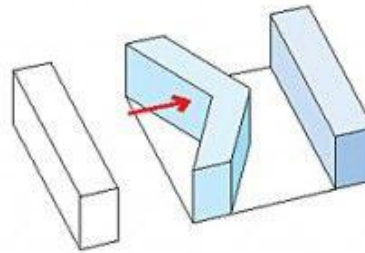

AVOIDING VIS-À-VIS

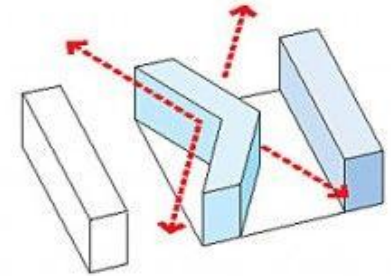

OPENING VIEWS OUTWARD

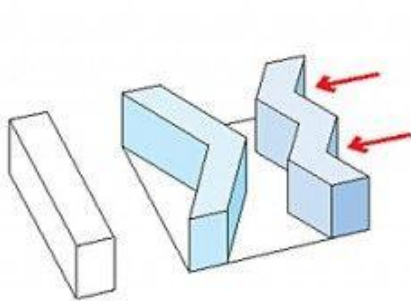

AVOIDING VIS-À-VIS

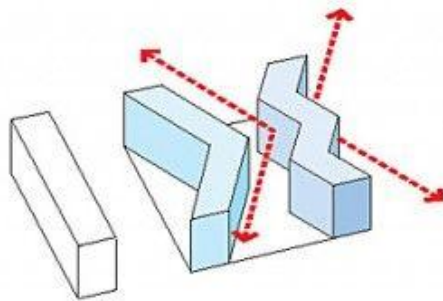

OPENING MORE VIEWS

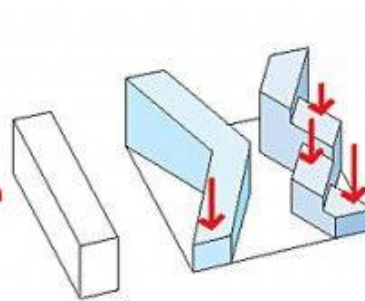

SLOPING & STEPPING DOWN

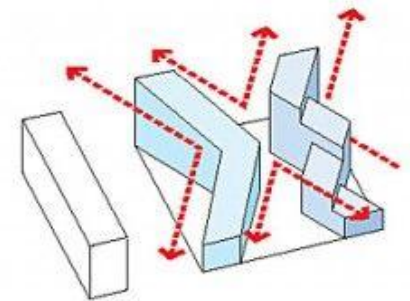

OPTIMAL VIEWS

Destacando elementos - espacios - interacciones con personas u otros espacios (interior-exterior)

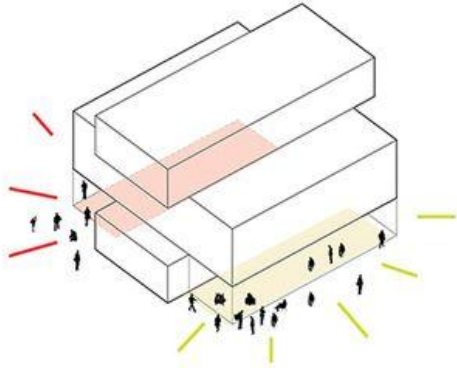

STRONG CONNECTION WITH PUBLIC SPACE

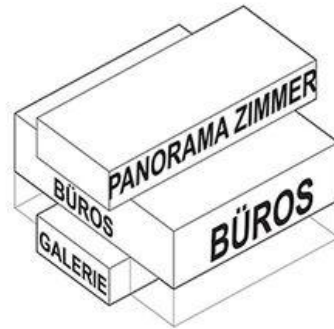

CLEAR PROGRAMMATIC IDENTITY

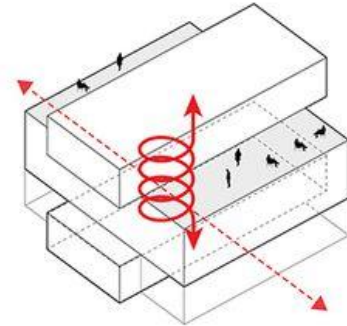

VERTICAL CONNECTION ACTIVE COMMUNICATION

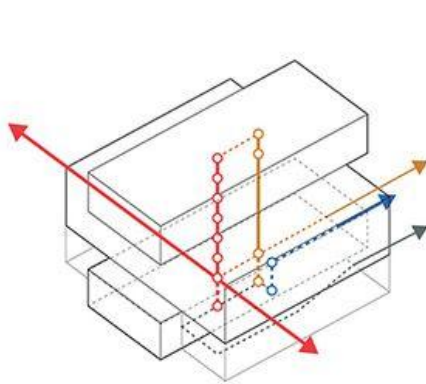

SEPARATE ORGANISATION PROGRAM

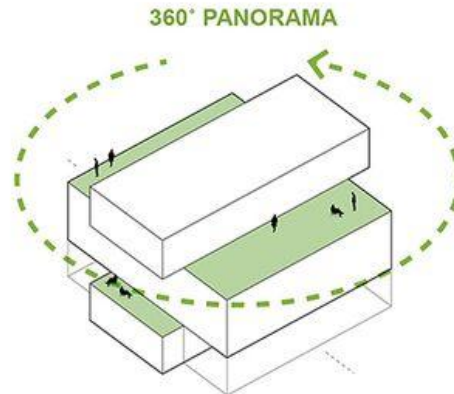

GENEROUS TERRACES

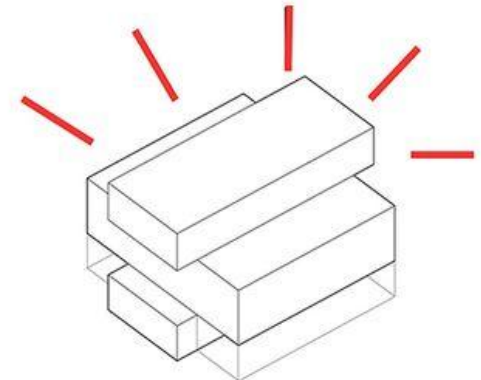

STRONG IDENTITY FOR KUNST-CAMPUS

Realizando dibujos de esquemas de líneas simples.

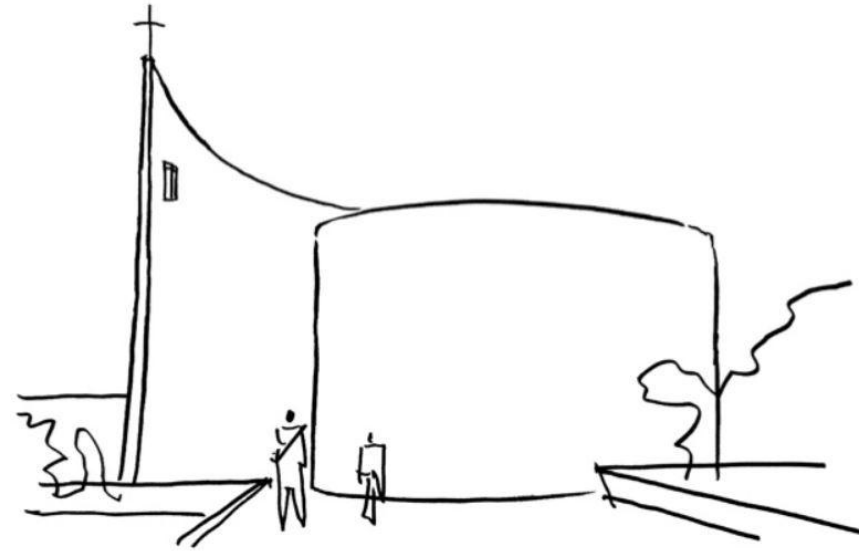
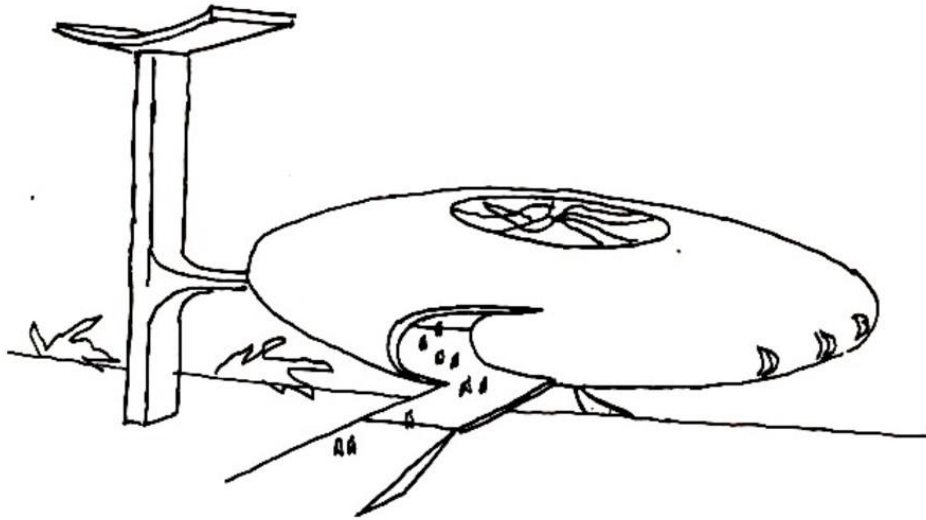

Ejemplos. Uso del dibujo para entender proyectos existentes.

Cuaderno de viaje.

Mario Roberto Álvarez.

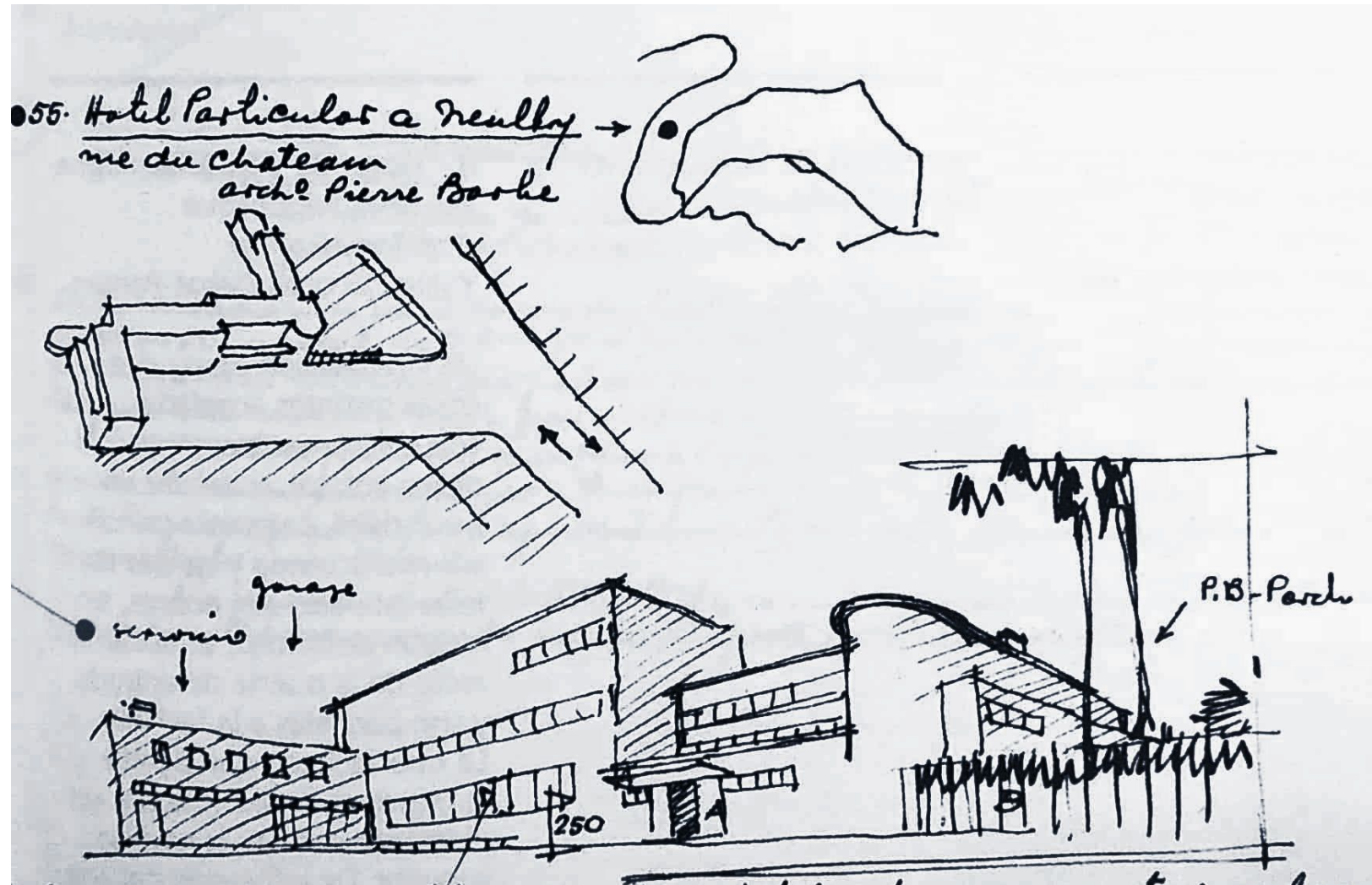

Formas de comunicar espacios e ideas. Perspectivas, cortes, vistas y plantas juntas en el papel.

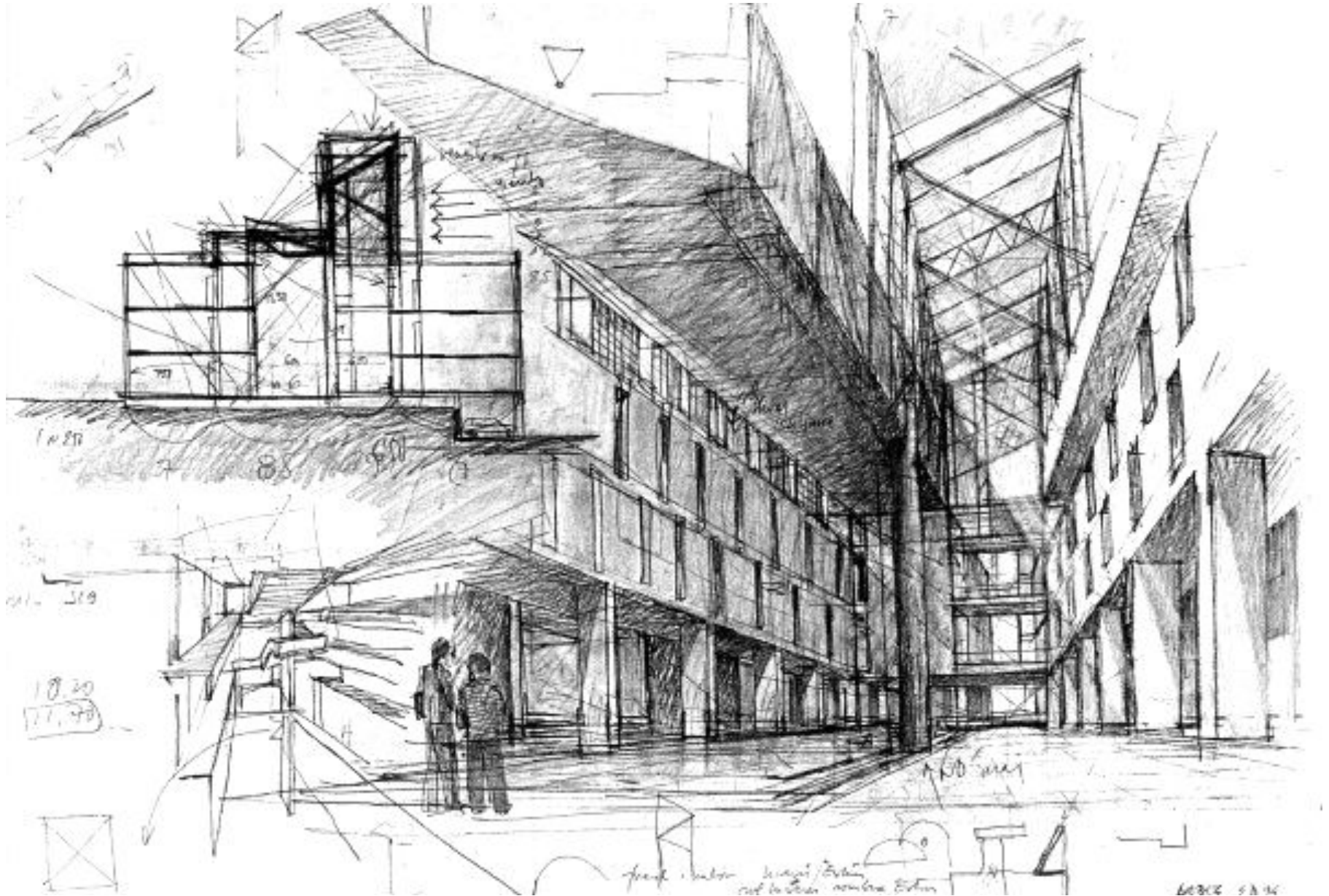

EJEMPLOS:
Síntesis

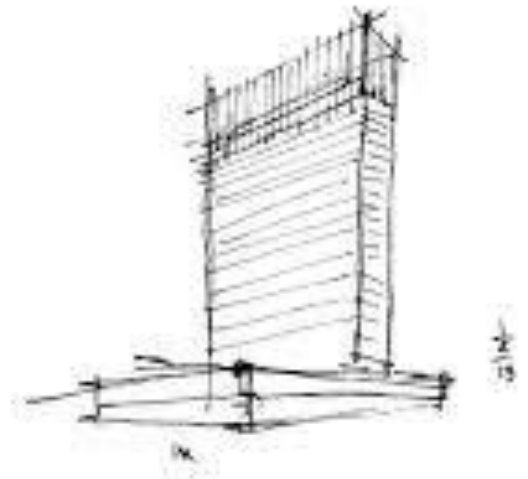
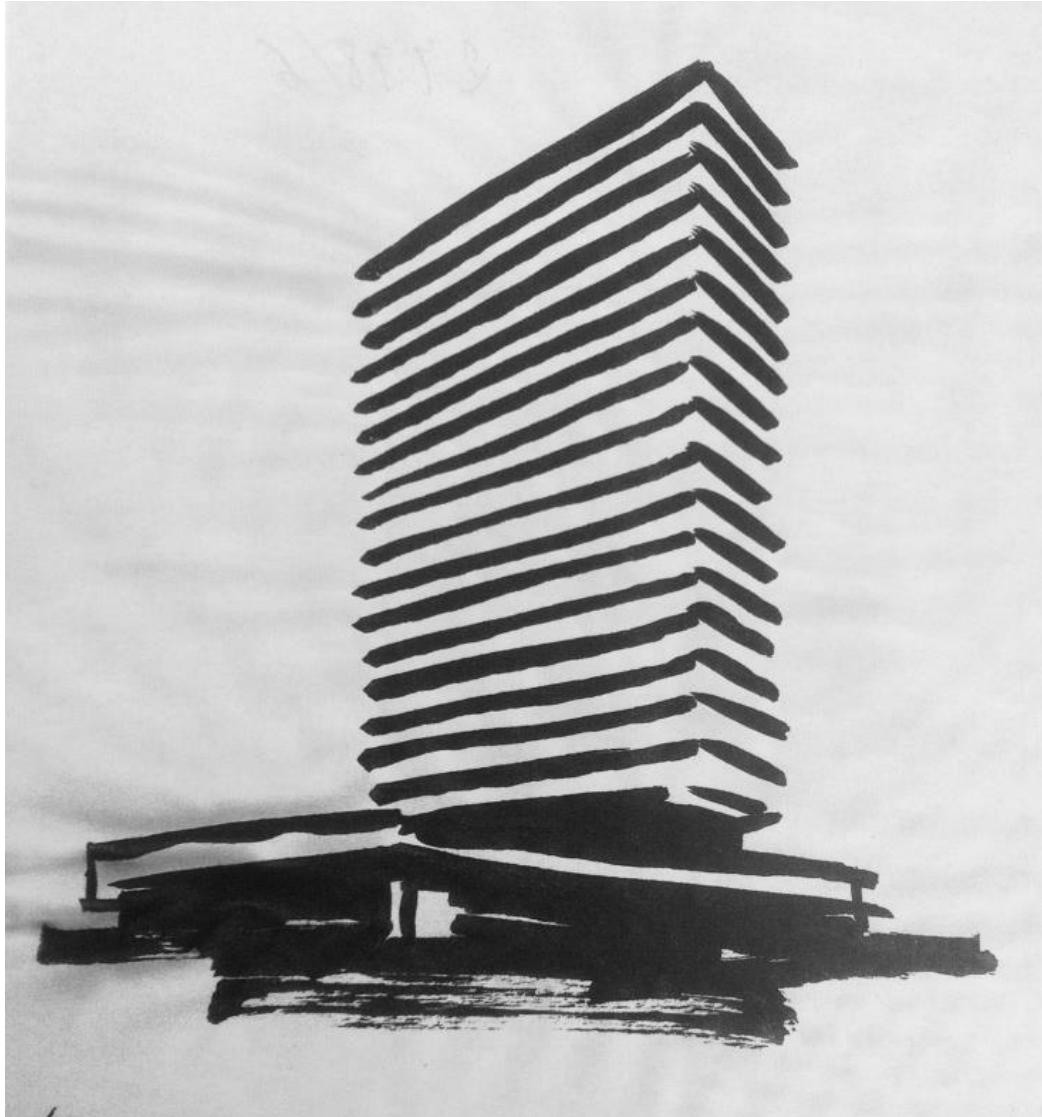



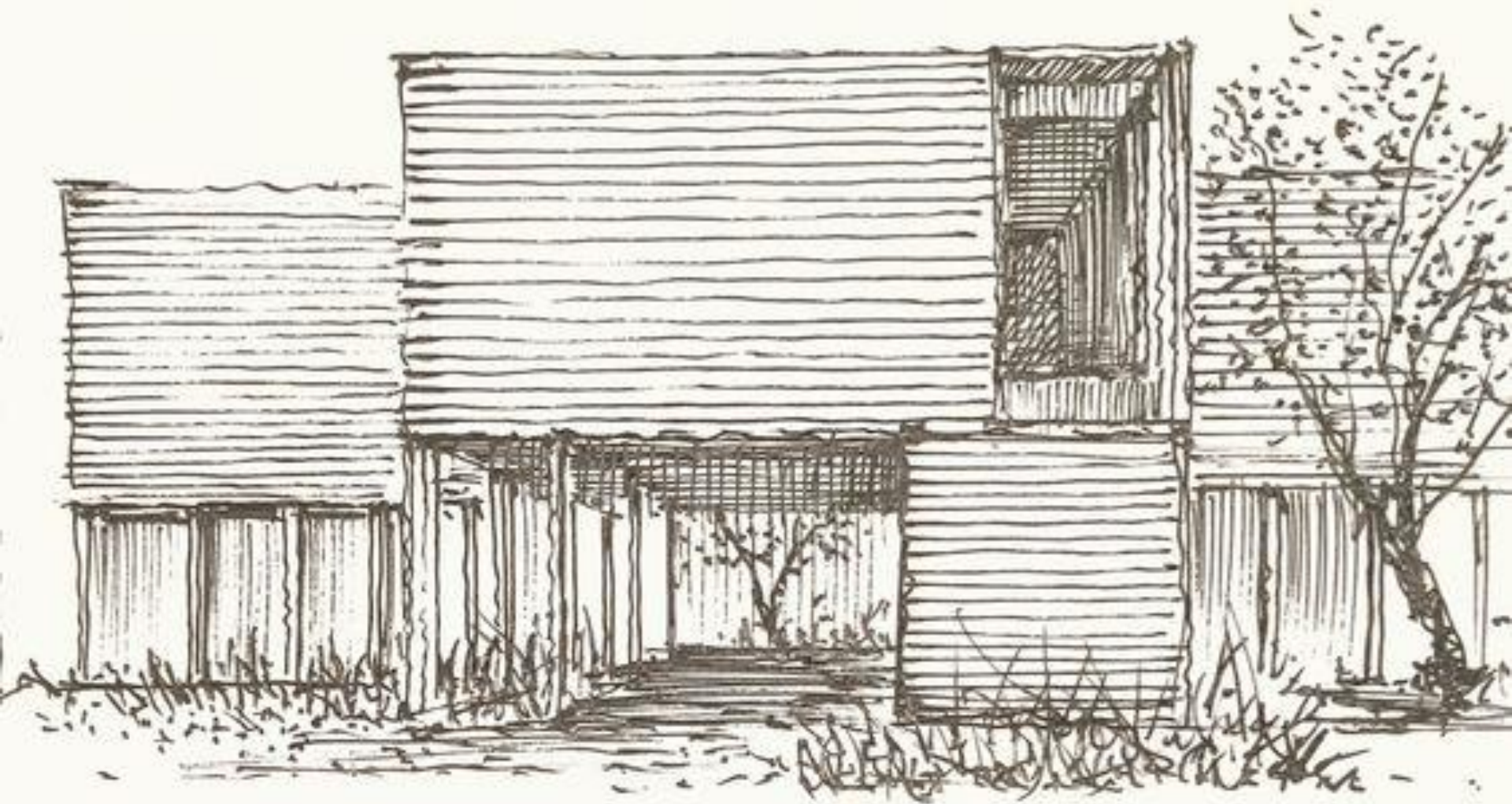

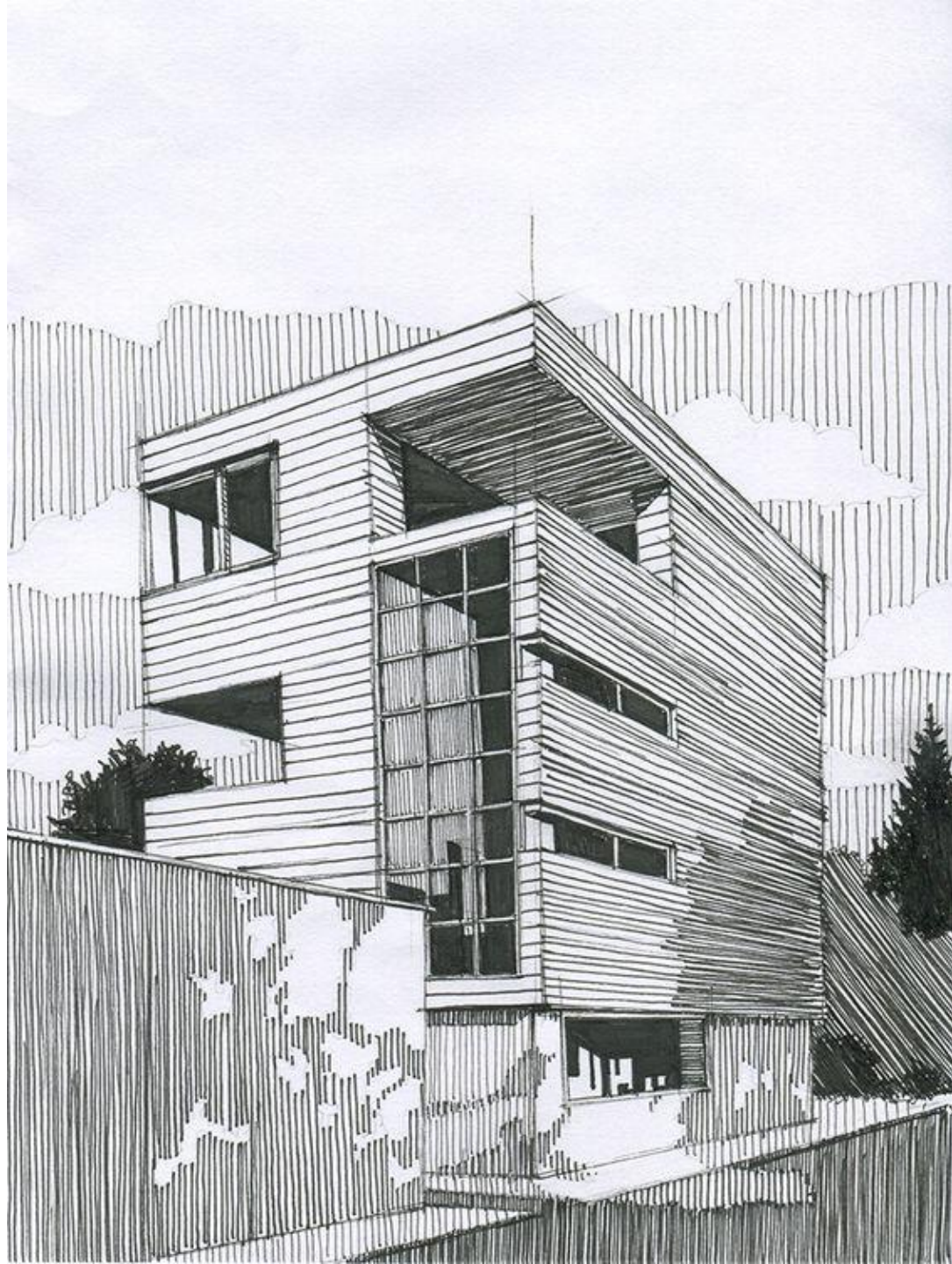

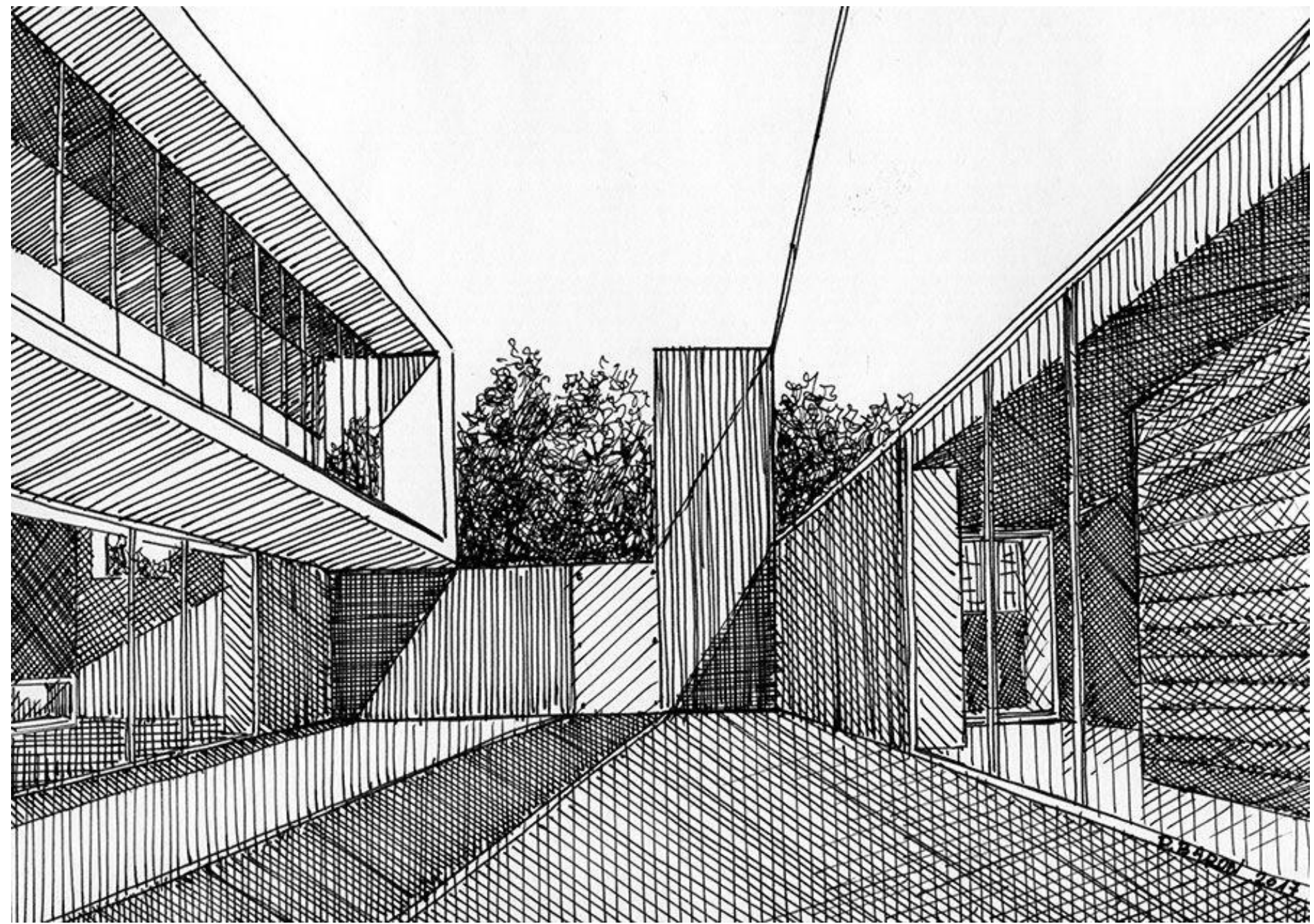

EL COLOR es el resultado de la interacción de tres variables: la LUZ, el OBJETO y el OBSERVADOR.

Percibimos los objetos a través de la forma, el tamaño, y el color.

Sin embargo el color de los objetos no es un atributo fijo e invariable, ya que depende de la fuente que los ilumina, las características del objeto -reflexión, transmisión y absorción - y también del observador.

Color y arquitectura. Chauvie/ Risso

CÍRCULO CROMÁTICO: primarios, secundarios (mezcla de dos primarios) y terciarios (mezcla de un primario y un secundario)

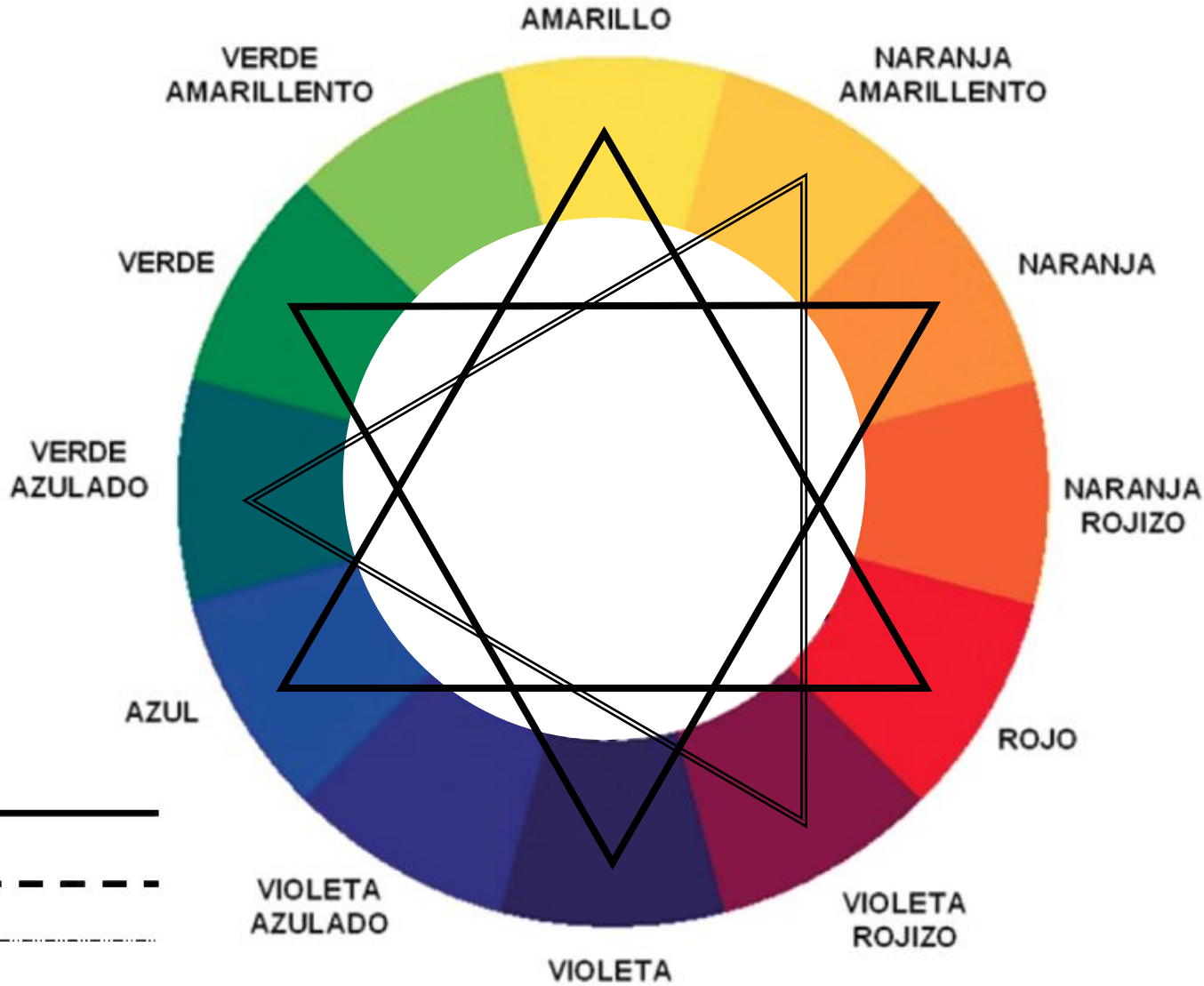

Primario ———
Secundario - - - - -
Terciario ·····

TEMPERATURA DEL COLOR: cálidos y fríos.

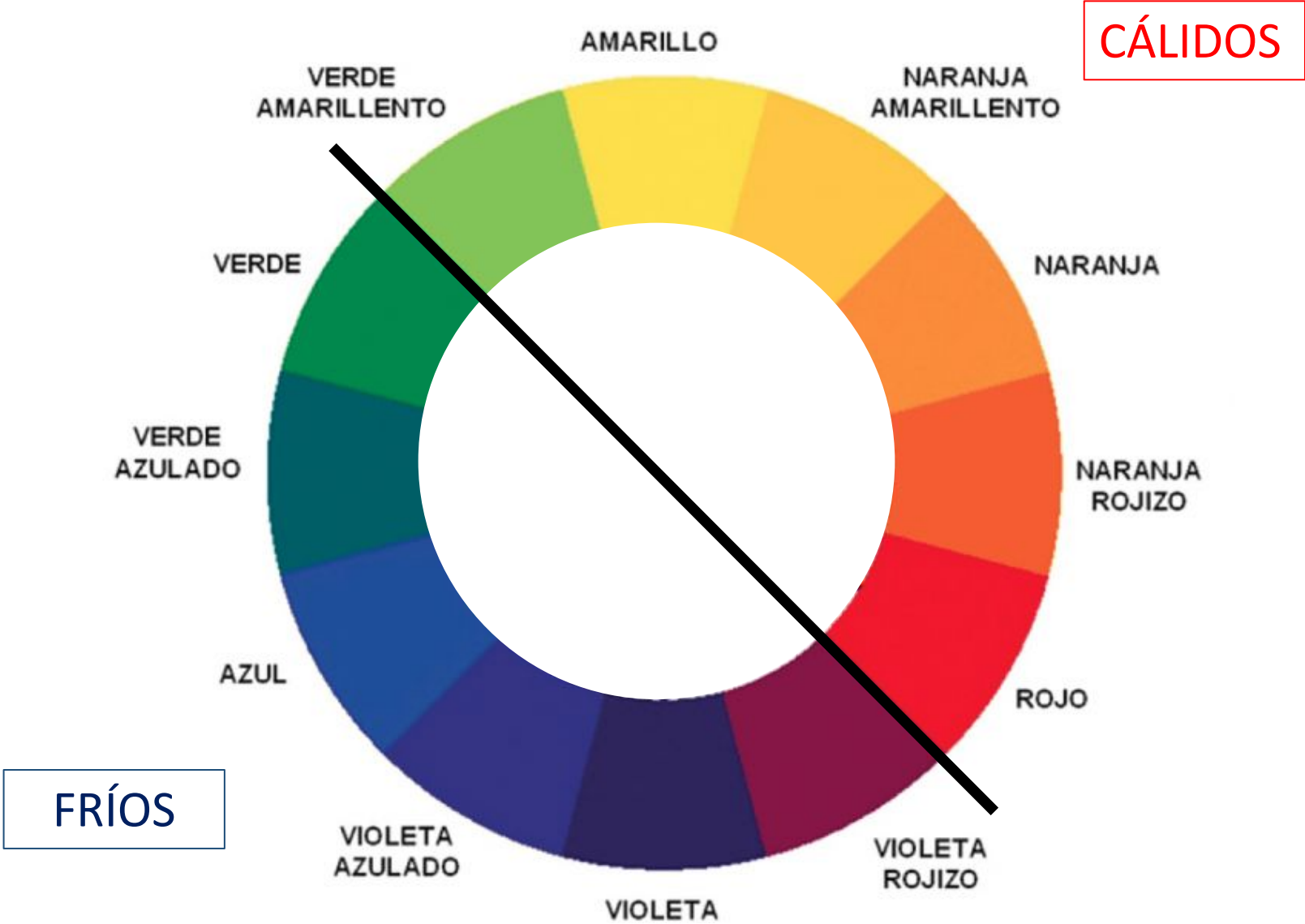

RELACIONES ENTRE COLORES: colores análogos o adyacentes

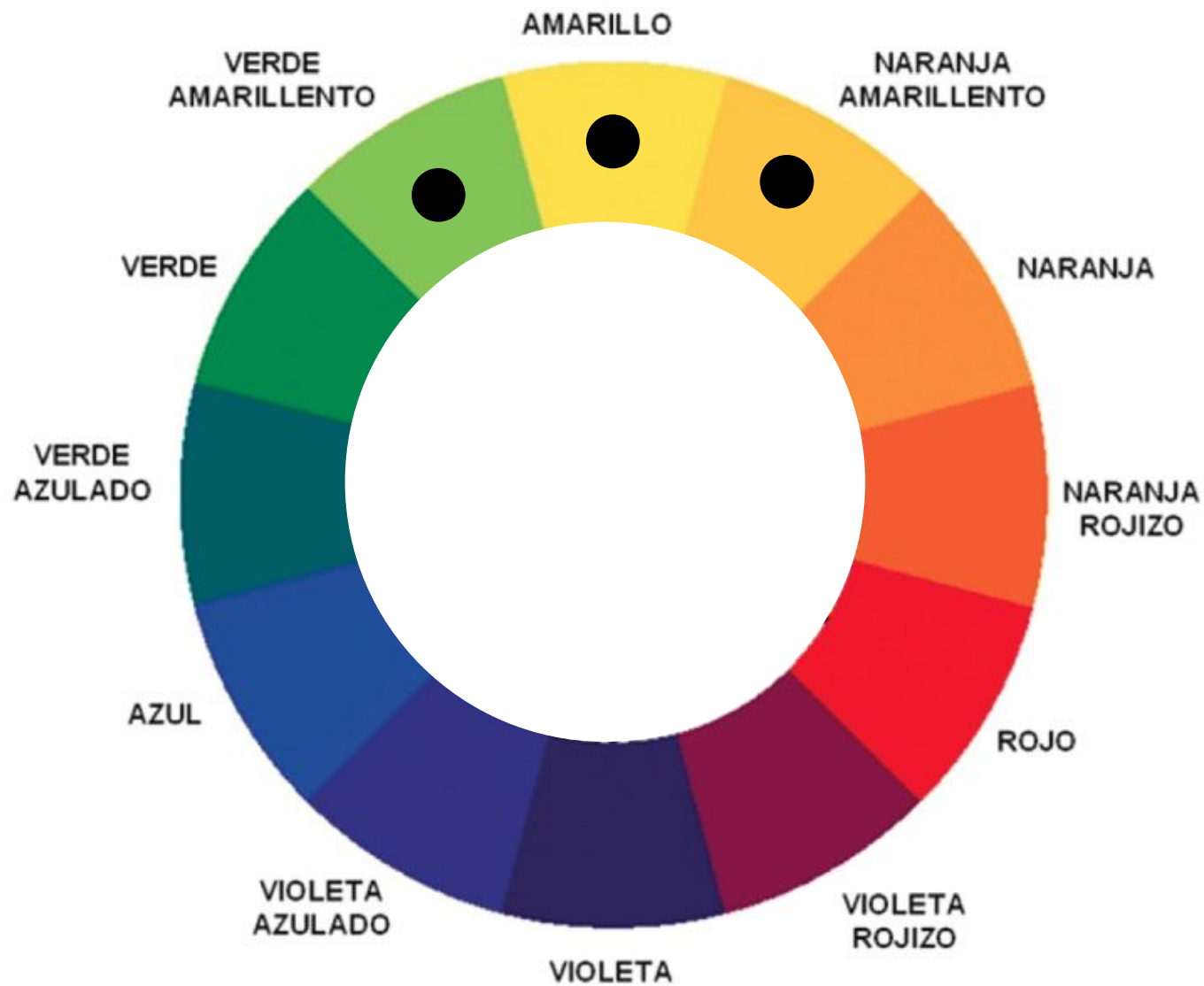

RELACIONES ENTRE COLORES: colores complementarios.

El complementario de un color primario es siempre uno secundario.

El complementario de un color terciario es siempre otro terciario.

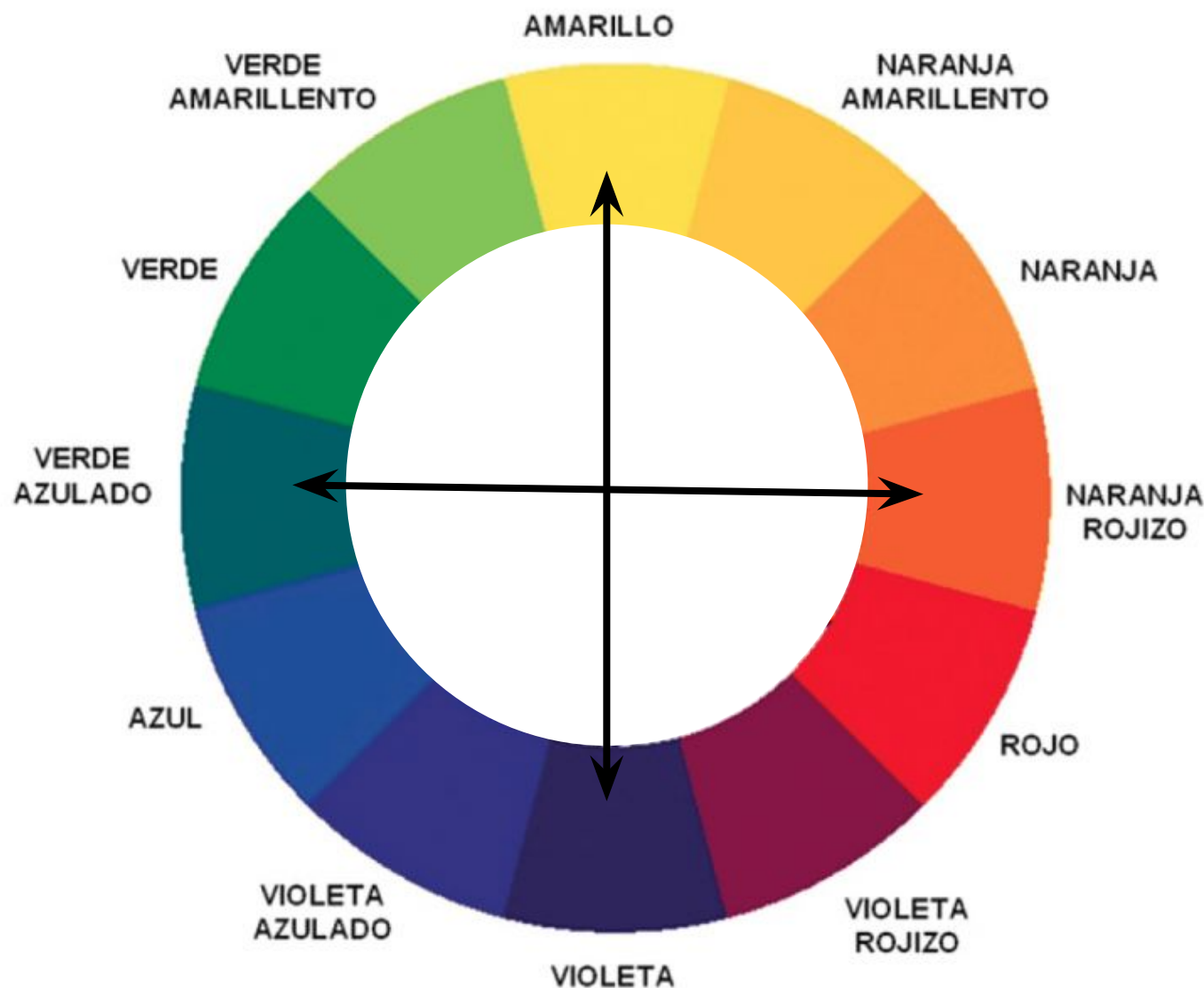

El TONO o matiz, es el grado de intensidad de un color.

La SATURACIÓN, se define por la cantidad de gris que contiene un color.

La LUMINOSIDAD o valor, se logra con la adición de blanco o negro a un color.

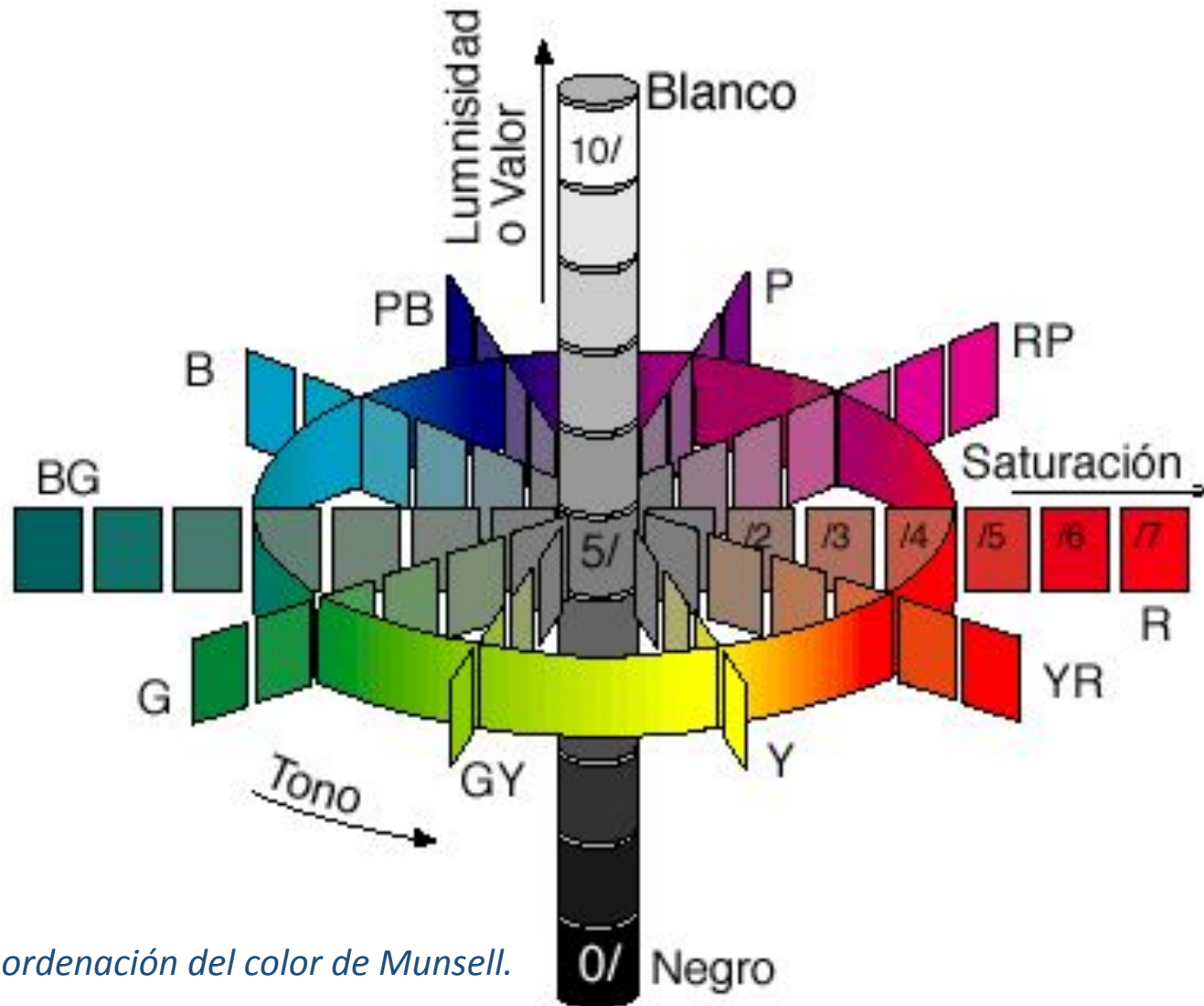

Sistema de ordenación del color de Munsell.

La SATURACIÓN, se define por la cantidad de gris que contiene un color.

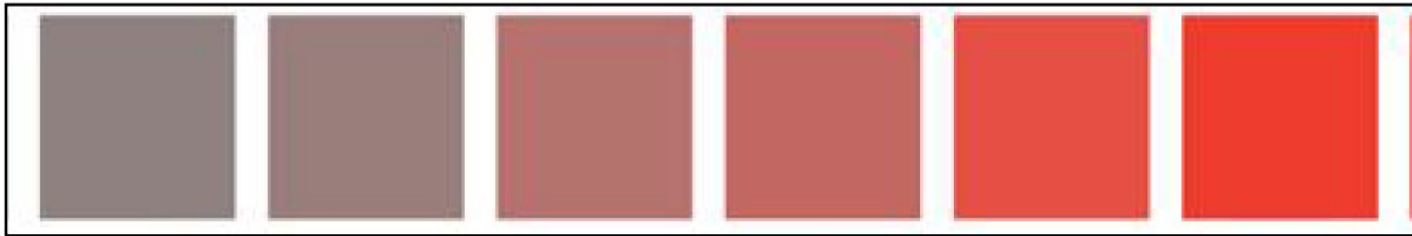

+ neutro

- saturación o brillo +

+ puro

La LUMINOSIDAD o valor, se logra con la adición de blanco o negro a un color.

escalas acromáticas

formada por los colores intermedios que existen entre dos colores dados.



escalas monocromáticas

son las escalas degradadas de un color adicionando negro o blanco.



escalas policromáticas

formada por los colores intermedios que existen entre dos colores dados.



Los colores que vemos en la pantalla son RGB mientras que los colores a la hora de la impresión son CMYK.

La razón es que la pantalla permite la visualización con millones de colores mientras la impresión es mucho más estricta.

Un archivo que se visualiza de una manera en digital no siempre corresponde al producto impreso.

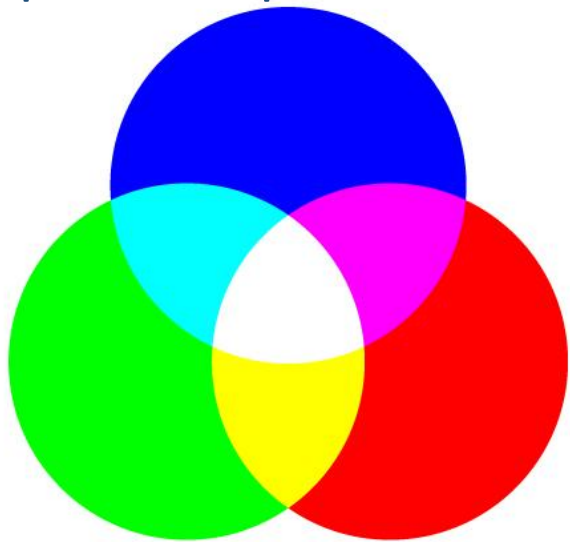

RGB

Rojo - Verde - Azul (Red - Green - Blue)
Es posible representar cualquier color por medio de la suma de los tres básicos. Sobreponiéndolos se obtiene el blanco.

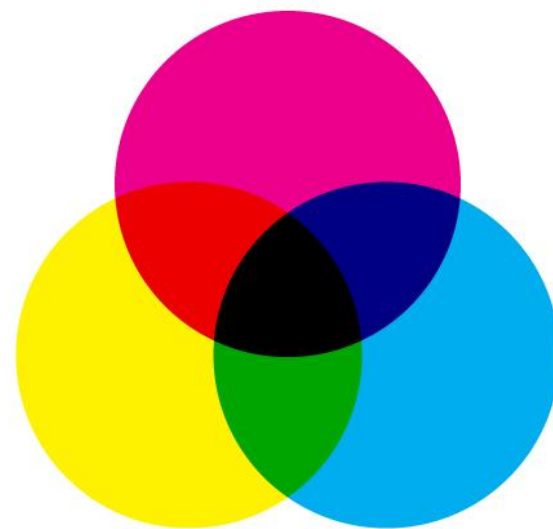

CMYK

Cian - Magenta - Amarillo - Negro (Cyan - Magenta - Yellow - Key Black). El color se obtiene por la diferente luminosidad. Sobreponiéndolos se obtiene el negro.

FORMULA GUIDE
Coated

FORMULA GUIDE Solid Coated

PANTONE®

Ink colors and
formulas for
packaging, print,
and graphics

FORMULA GUIDE
Uncoated

FORMULA GUIDE Solid Uncoated

PANTONE®

Ink colors and
formulas for
packaging, print,
and graphics

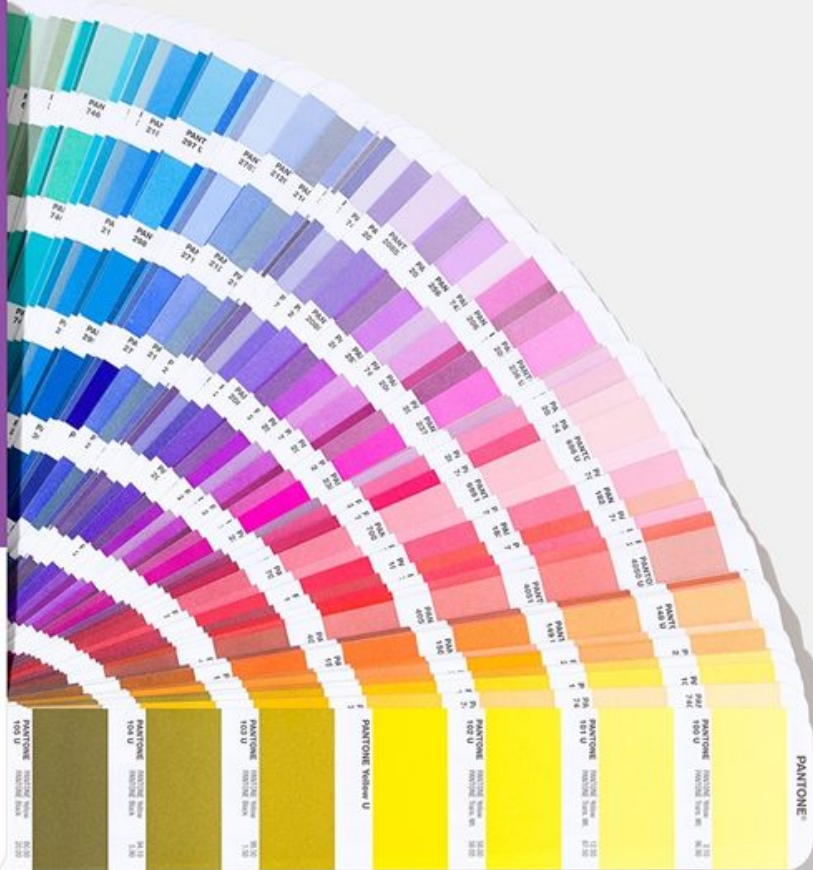

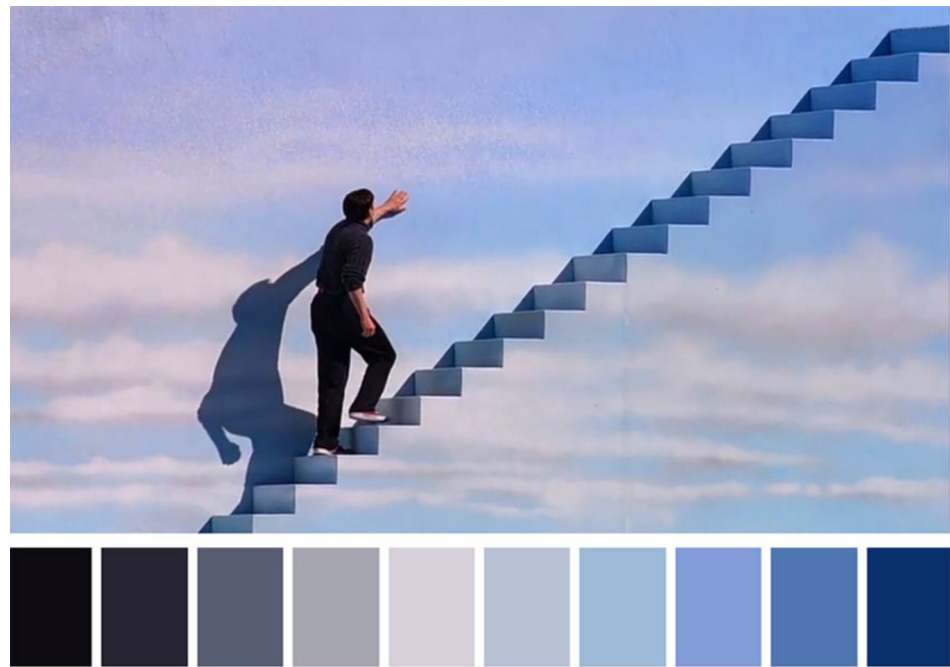

El color contribuye a la lectura de la forma arquitectónica.

Tiene la capacidad de clarificar los componentes de la forma o confundirlos, enriqueciendo la percepción de una obra arquitectónica o de un espacio.



Color y arquitectura. Chauvie/ Riso

El color en la representación material.





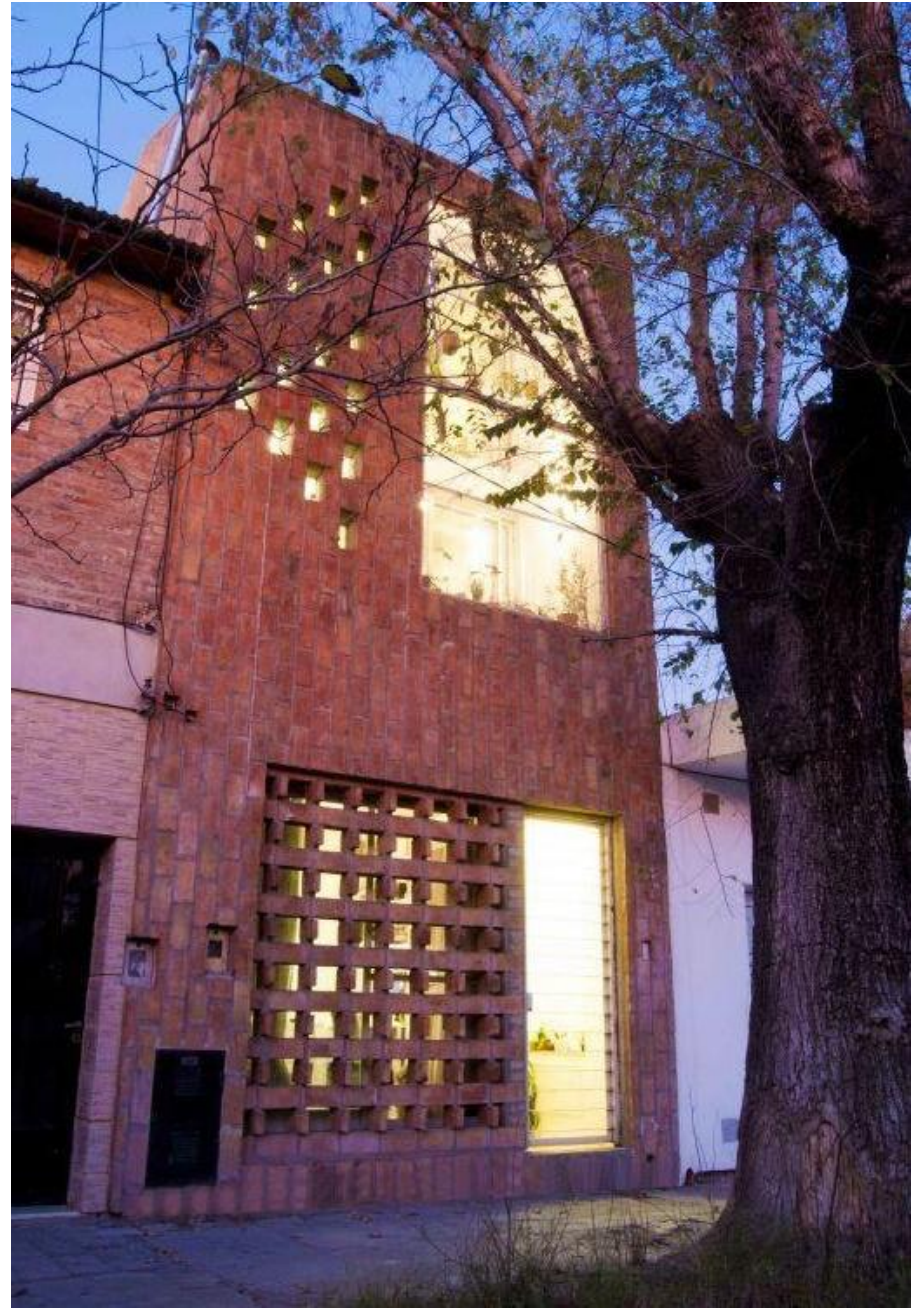

El color en el croquis.

Saturacion



EJEMPLOS:
Foco y entorno / resaltado – desdibujado

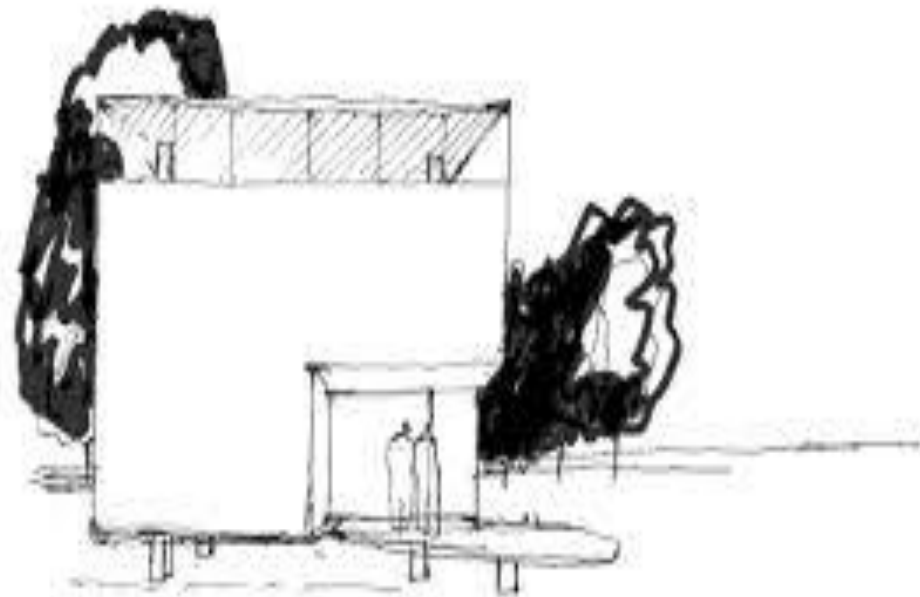

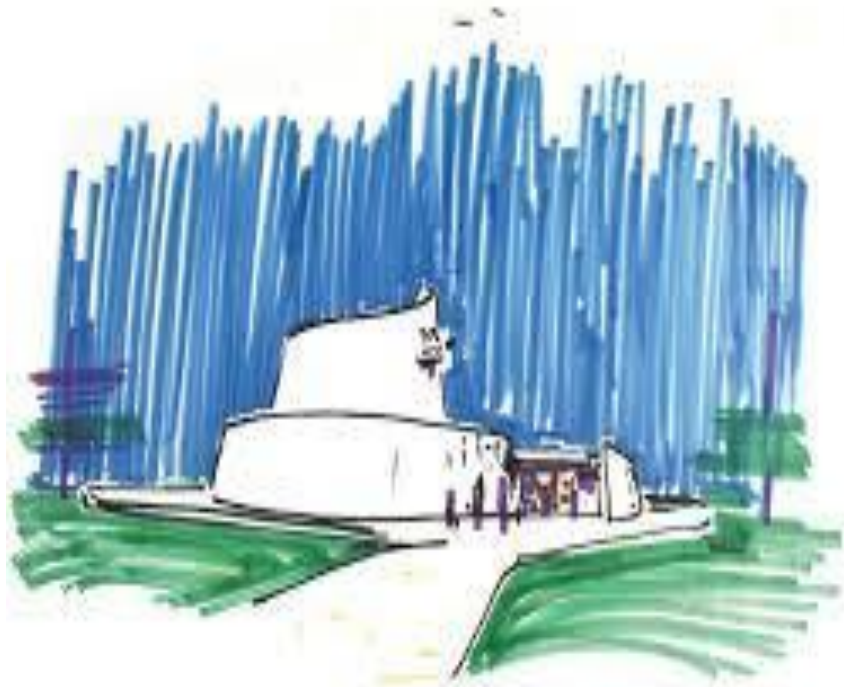

Plan 04. 10. 20

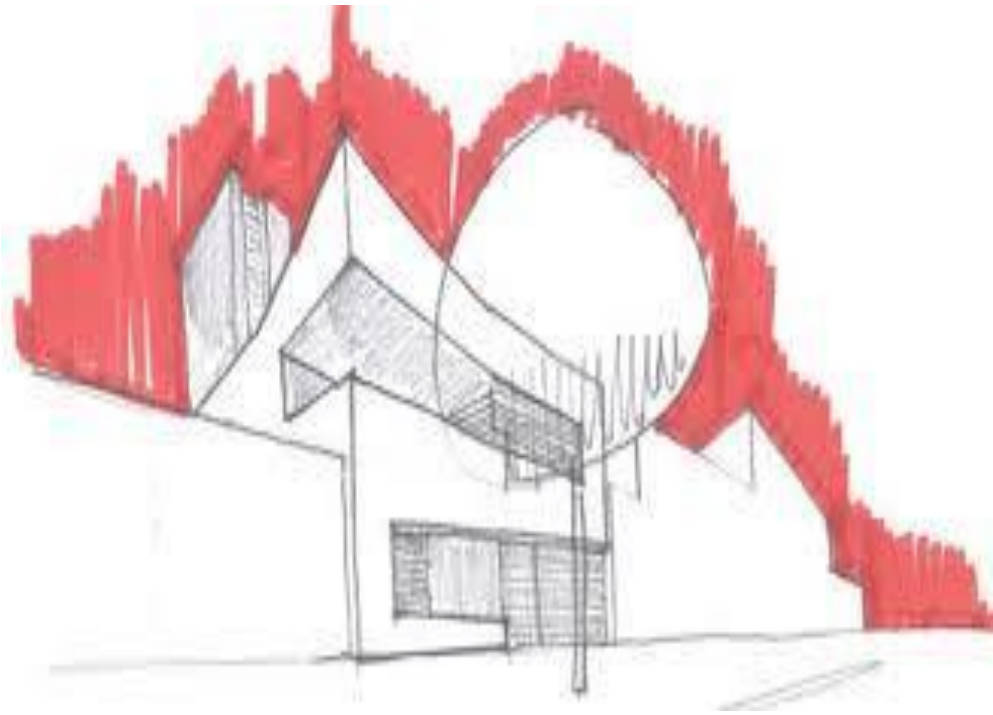



El color en la comunicación de la idea.

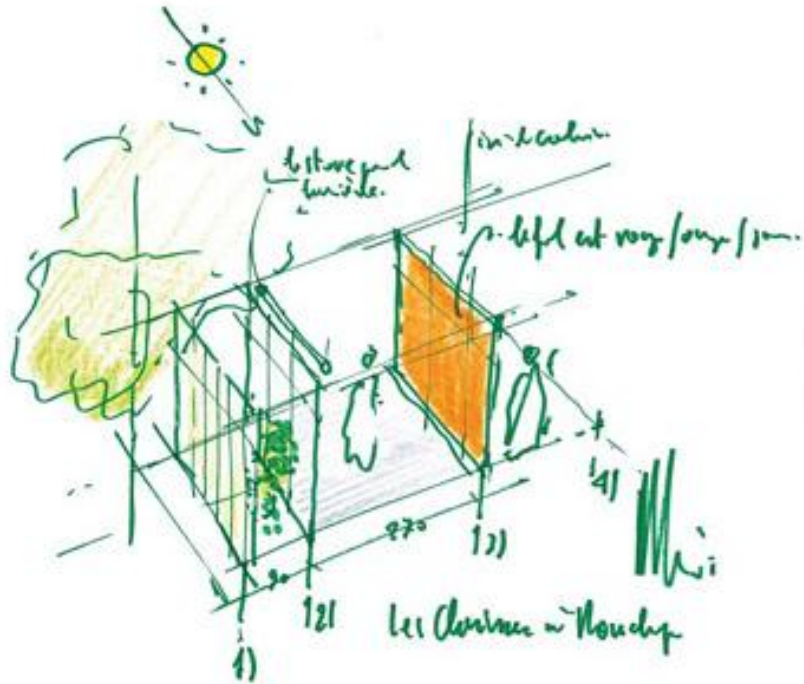

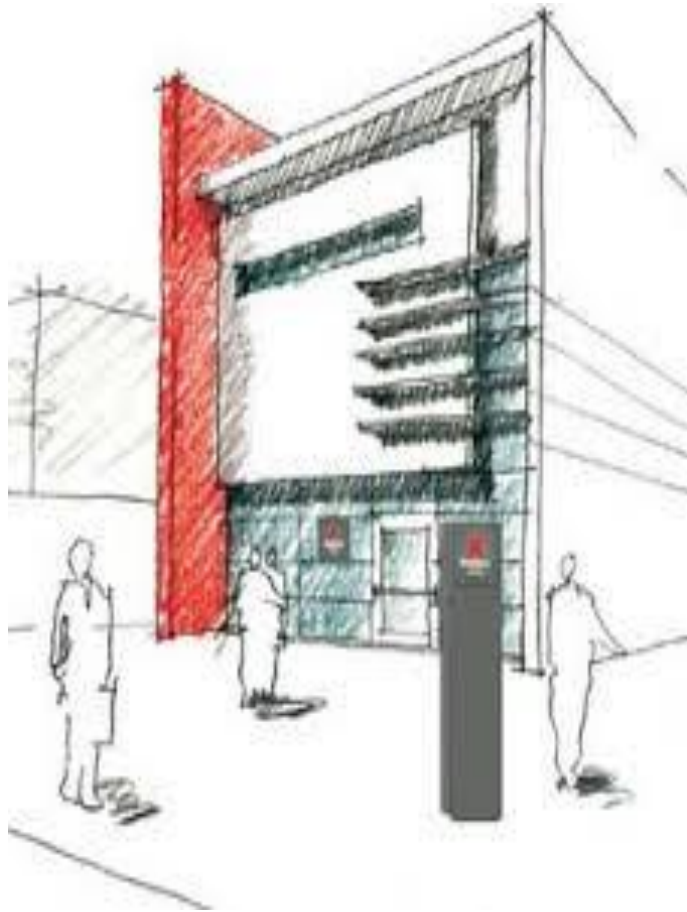

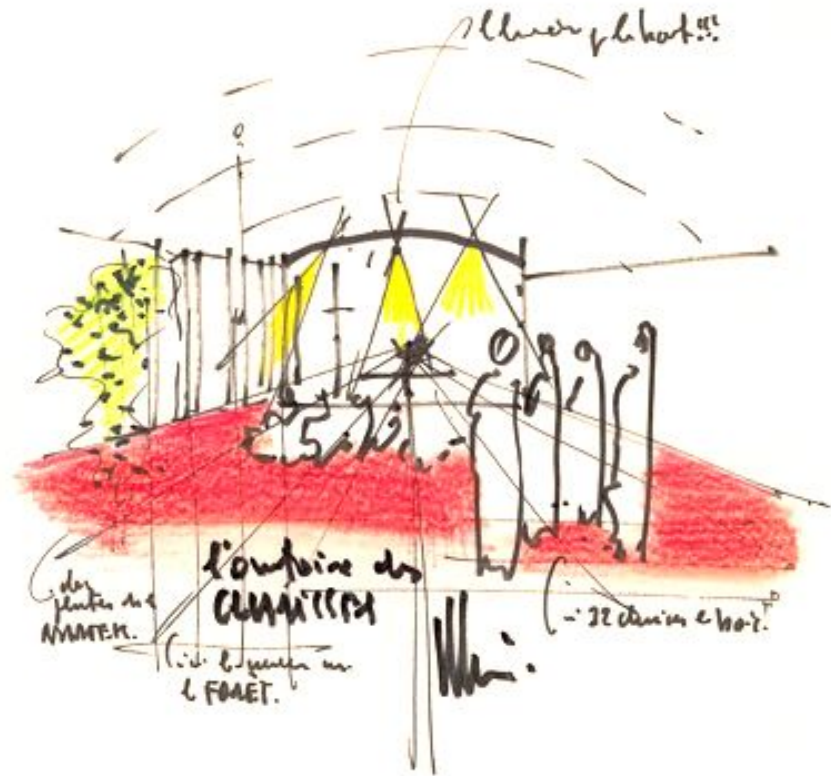
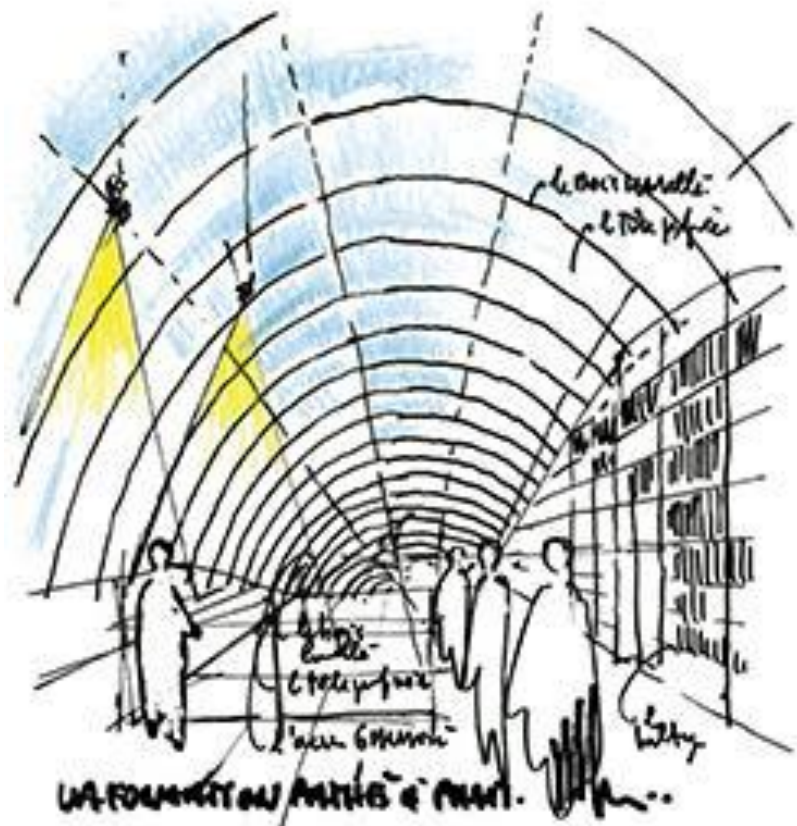

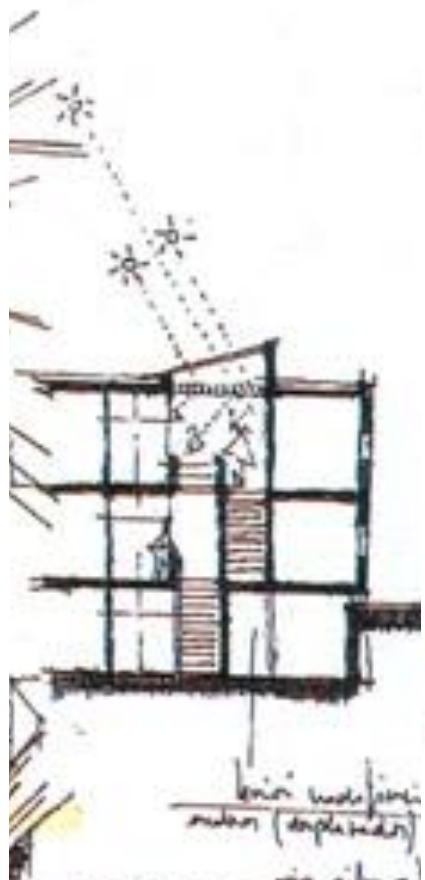

brici wadifonin da malar (daplataci)

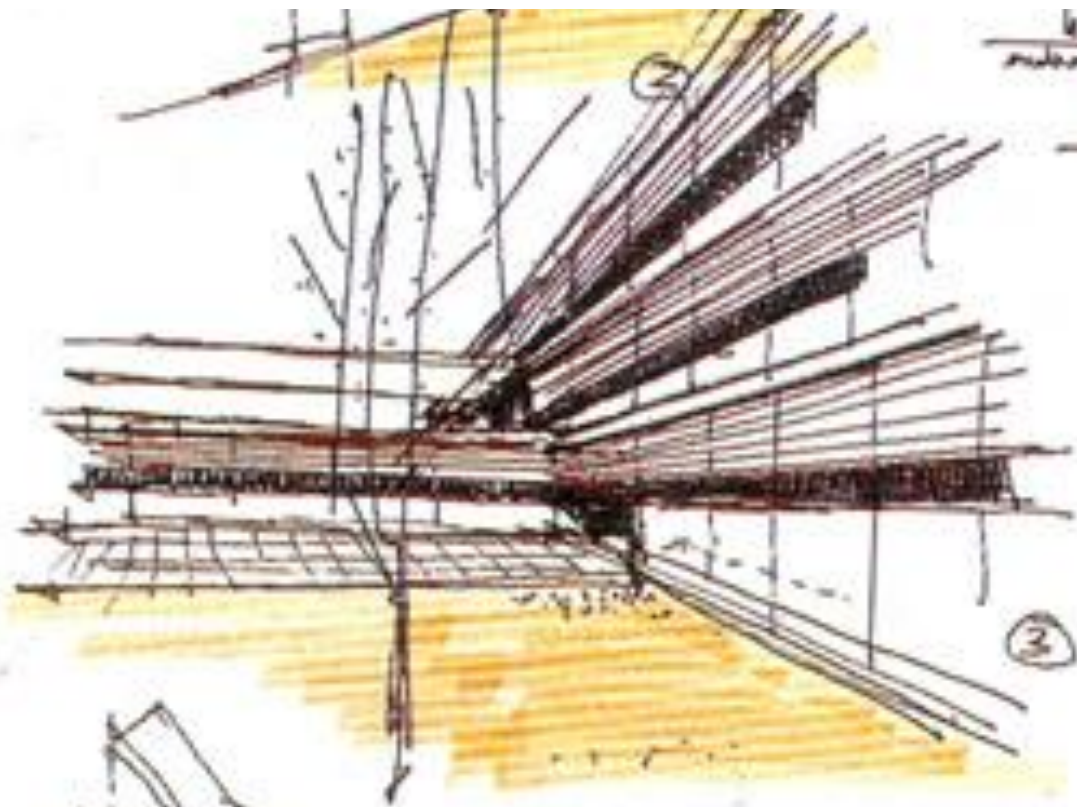

brici wadifonin da malar (daplataci)
vio. piba 7 balaba

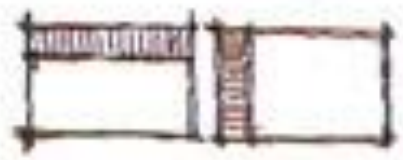
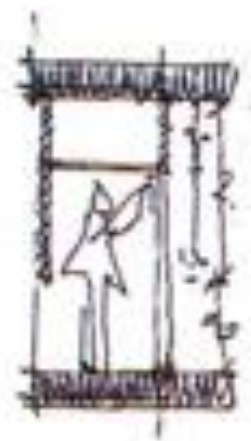

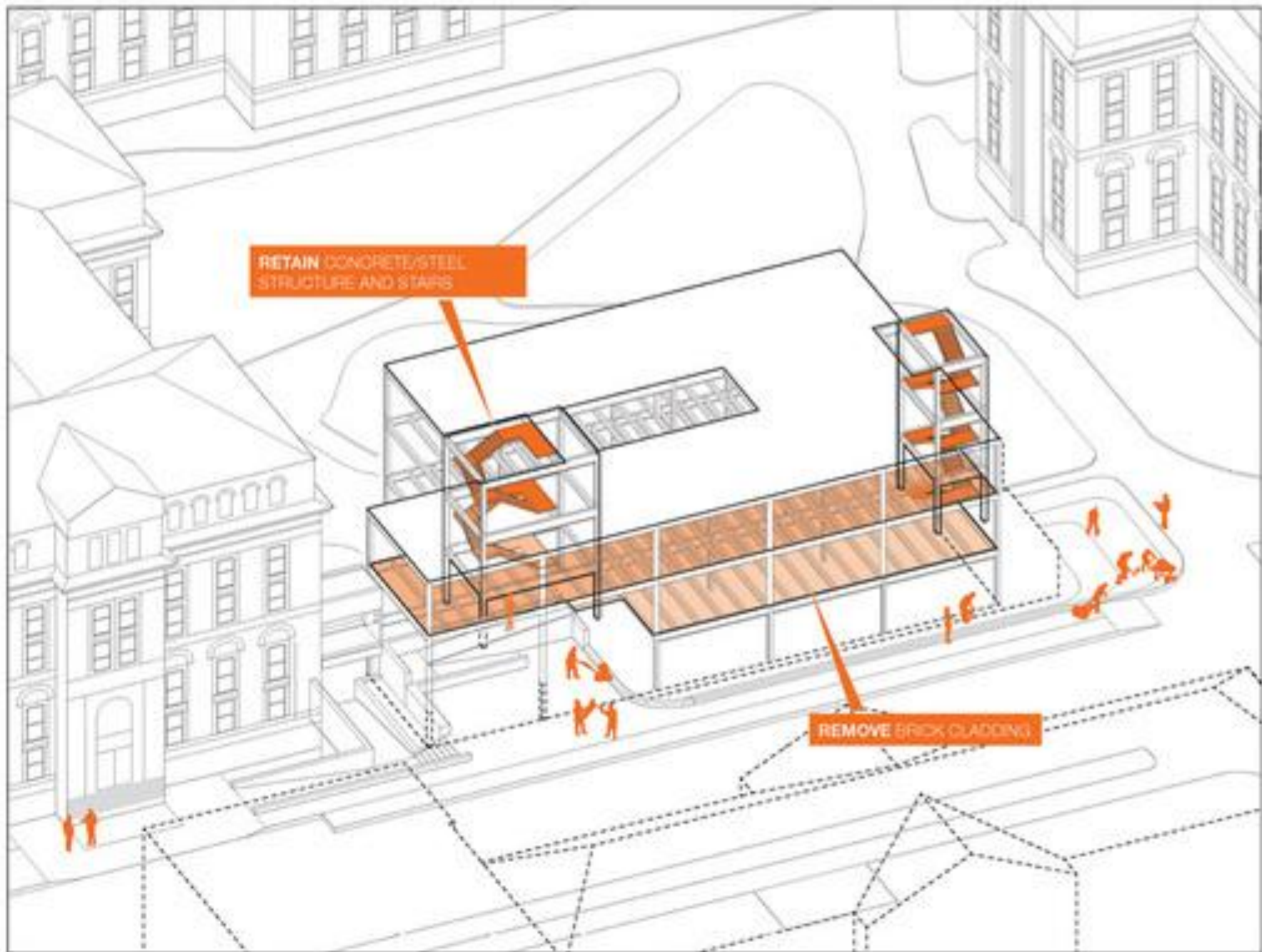



103.305 m²
dedicados al arte
contemporáneo
en el centro
de París

Su estructura
está formada por
15.000 toneladas
de acero

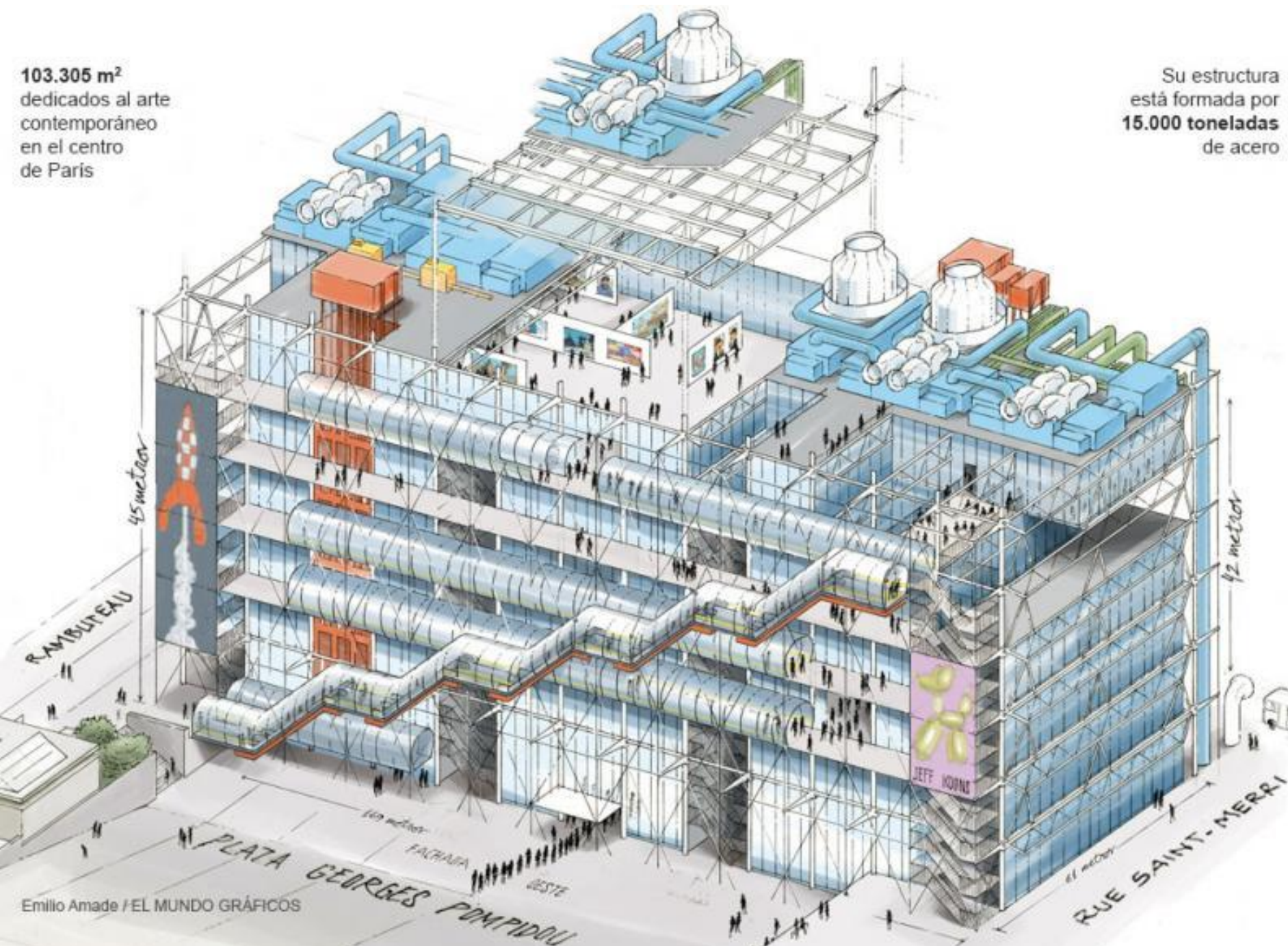

Proyecto.
Vivienda
Hampton - Rivoira.

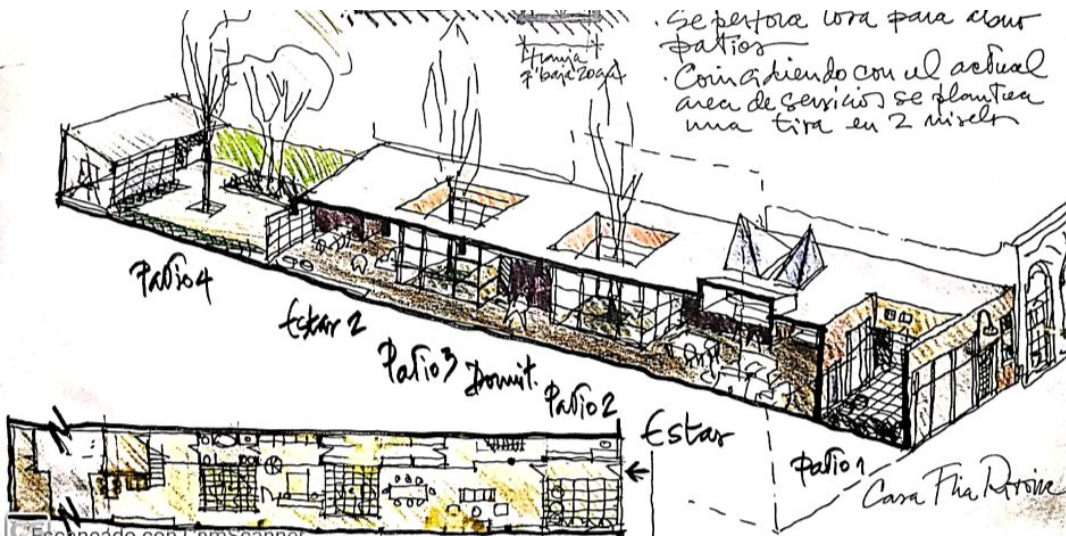

Proyecto.
Mercado Santa Caterina. Remodelación.
Enric Miralles y Benedetta Tagliabue.



Proyecto.
Vivienda en Calamuchita.
Miguel Ángel Roca.

► Croquis. Javier Bossi.



Proyecto. Vivienda Chiera.
Hampton - Rivoira.

Chiera, publicada en el n.º 2 de 1966.

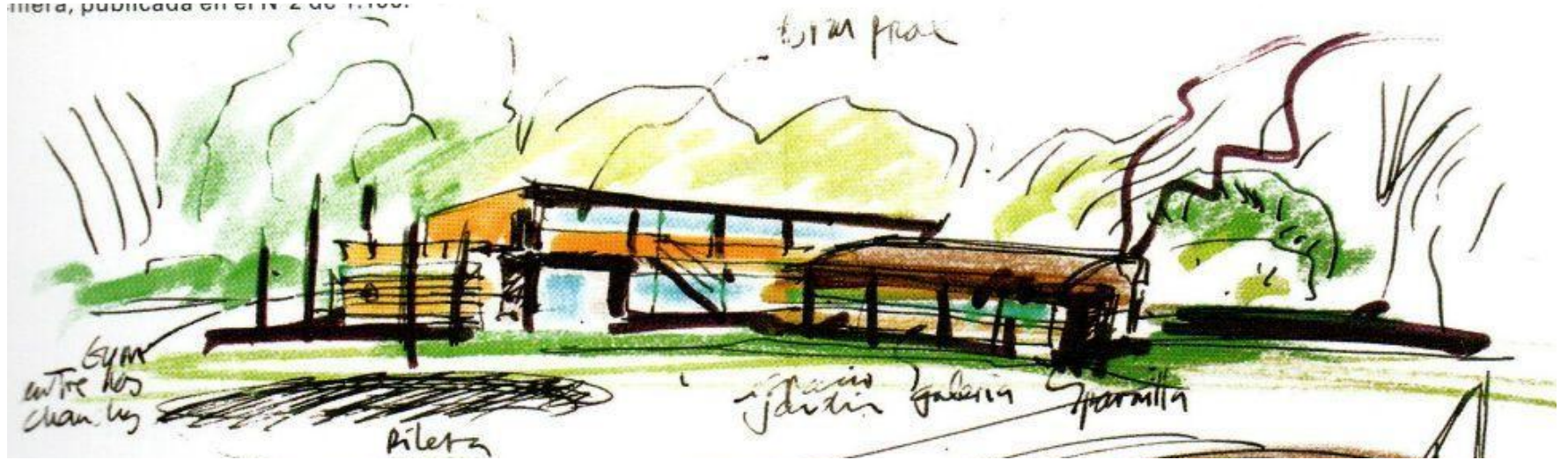

Proyecto. Vivienda Chiera.
Hampton - Rivoira.

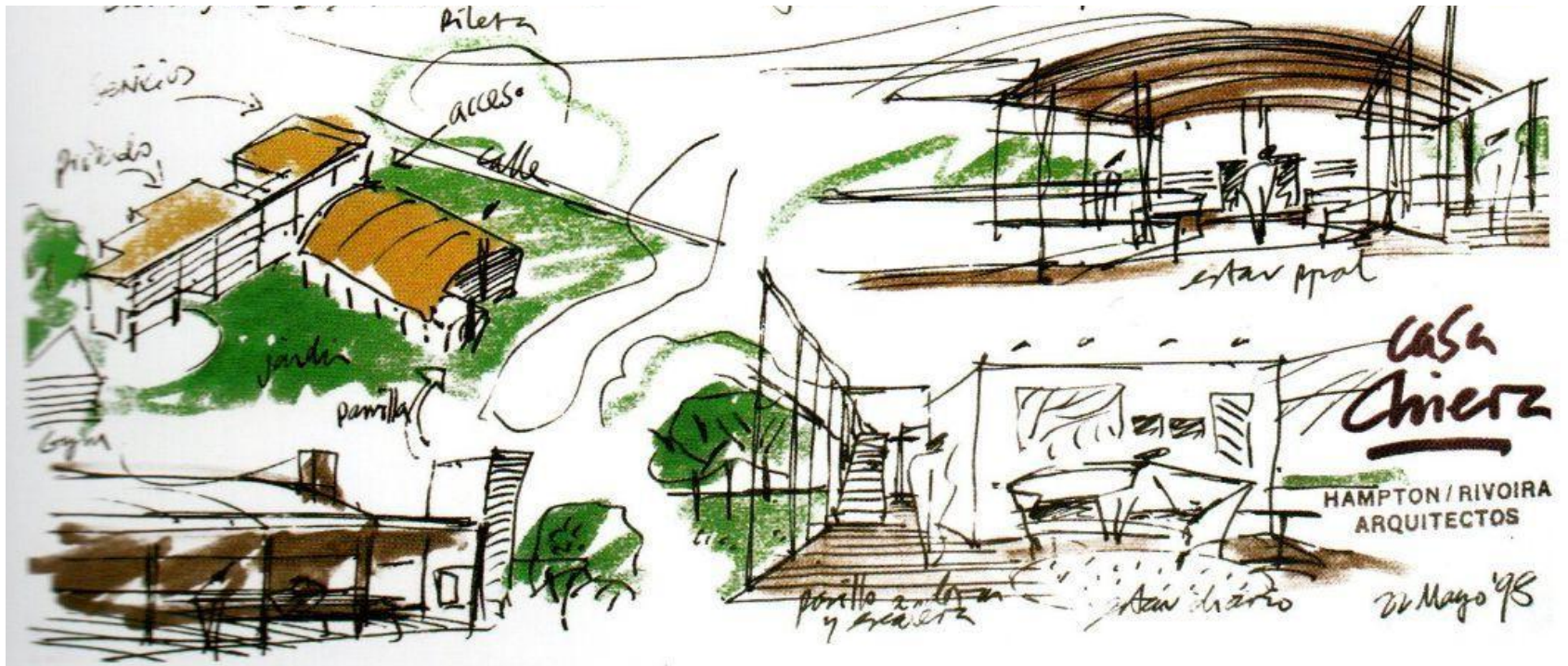

Proyecto.
Vivienda
Eladio Dieste.

